

Beveled 90° Clamp Glass-to-Glass Closed Face



SKU.BGC590-CF

Recommendations:

Use only tempered safety glass.
Do not use power tools for tightening the Clamp clamping plate

Maintenance guidelines:

You should never apply an abrasive cleaner on hardware. Drying the hardware with a soft towel after each use is the most effective way to get the most out of our hardware. To clean our hardware a little bit of mild dish soap and warm water should be applied using a non-abrasive cloth or towel. Rinse with clean warm water and then dry. Doing this after each use will ensure the longest life possible for the hardware. Leave the shower door slightly open to allow air to circulate; this will discourage the growth of mildew. Another important cleaning technique for shower doors is to squeegee after showering. It removes excess moisture from the shower and avoids water spots that can be difficult and almost impossible to remove. A plastic squeegee is best because metal could damage a shower.

Specifications:

Glass Sizes: 3/8" (10mm) to 1/2" (12mm) thick tempered safety glass
Construction: Solid brass
Cutout Required
Includes: Gaskets, screws and template

Use of Gaskets:
For 3/8" (10mm) Glass: Use one thick gasket on each side
For 1/2"(12mm) Glass: Use one thin gasket on each side

FRONT VIEW

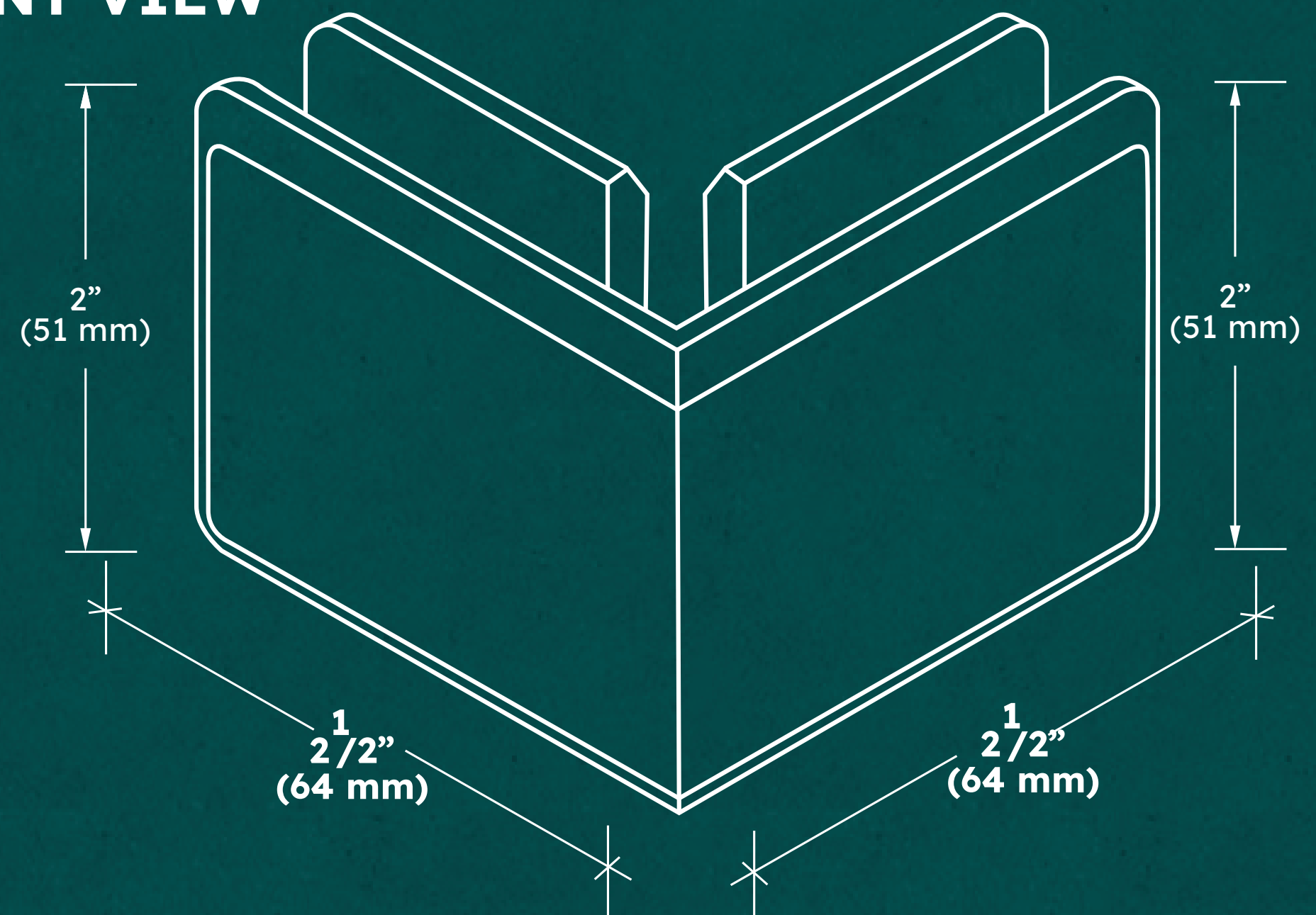

REAR VIEW

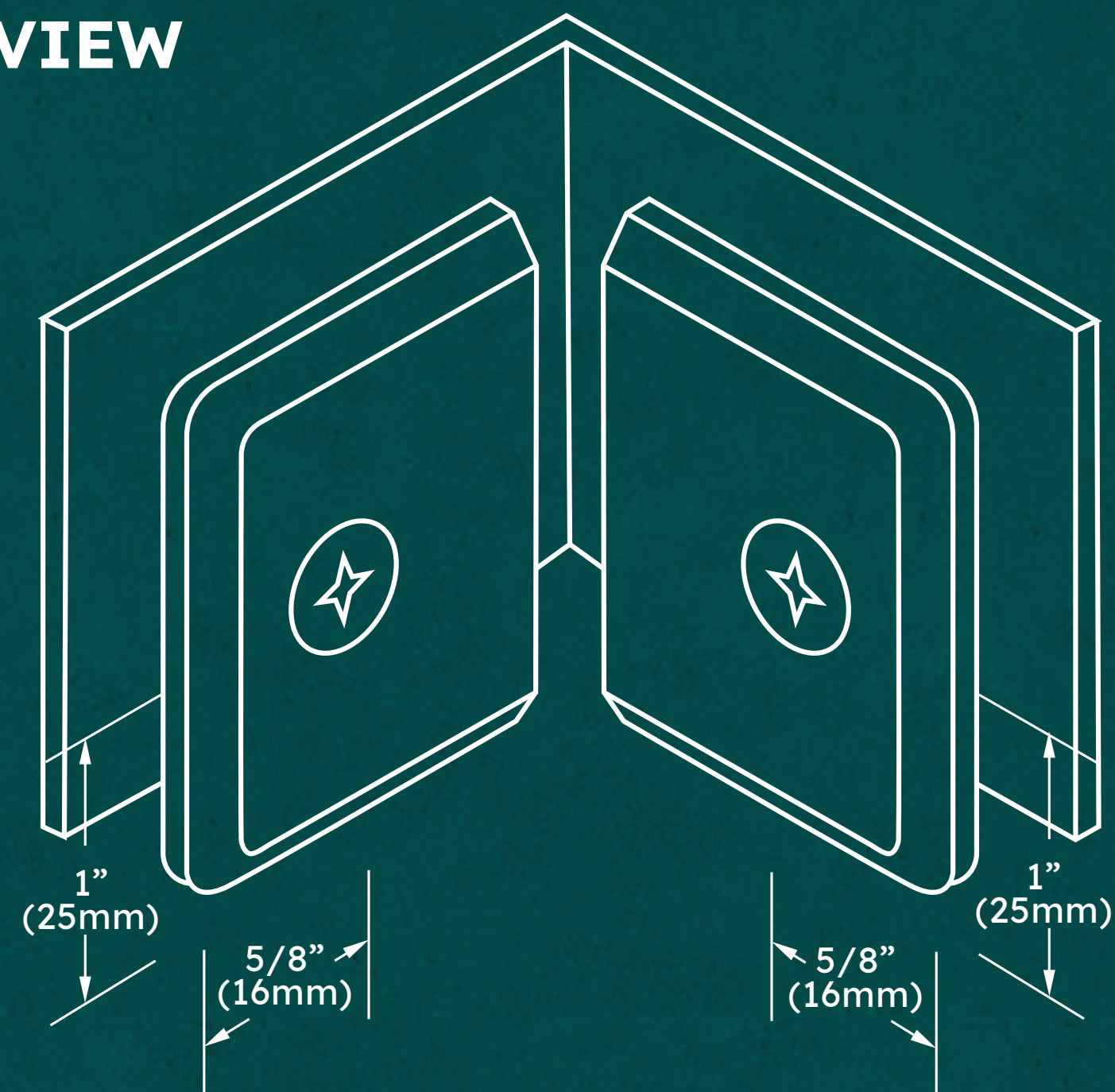

Beveled 90° Clamp Glass-to-Glass Closed Face



SKU.BGC590-CF

