

# INSTALLATION INSTRUCTIONS

## DYNASTY SYSTEM DEGREE BYPASS DYNA-SYSTEM FRAMELESS SLIDING SHOWER DOOR KIT.

- Designed for Use With 3/8" (10 mm) Tempered Glass
- 2" (50.8mm) Low Profile Header
- Easy to Install
- High Quality Stainless Steel Construction
- Matte Black Finish is Also Available

Our Popular **Dynasty System Series Frameless Sliding Shower Door Kits** offer a low-profile header track and glass rollers that are designed and manufactured from heavy-duty durable stainless-steel. Each glass roller requires one 3/4" (19mm) diameter hole for proper mounting. Precision bearings and stainless-steel wheels also offer a quiet glide opening and closing operation. Another nice feature, this system can be installed in a wide range of shower applications from full standing shower enclosures or on top of bath tubs.

One standard size fit's most 180-degree bypass inline applications. Stock Available Size: 73" Wide Kit

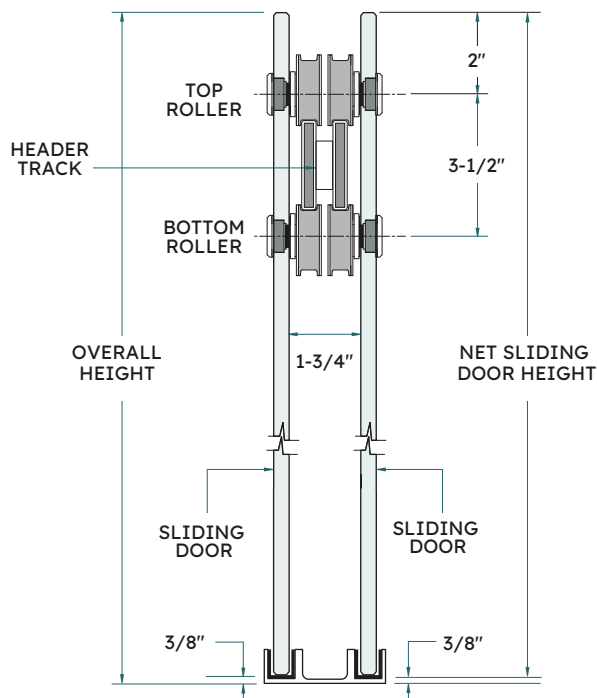

SECTION VIEW OF SLIDING SHOWER KIT

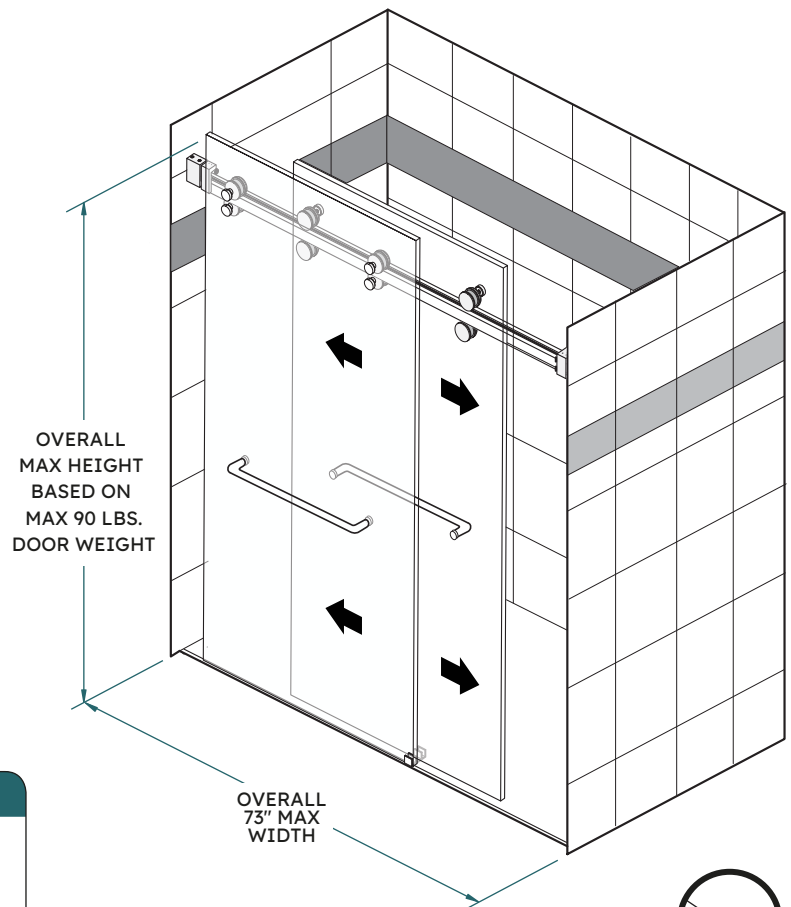

OVERALL  
MAX HEIGHT  
BASED ON  
MAX 90 LBS.  
DOOR WEIGHT

OVERALL  
73" MAX  
WIDTH



USE ONLY  
MONOLITHIC  
TEMPERED GLASS

### SPECIFICATIONS

Material: Header Track and Hardware, (Stainless Steel)  
Glass Thickness: 3/8" (10mm) (Glass is not Included)  
Glass Fabrication: Each Included Glass Roller requires one 3/4" Diameter Hole. Two 1/2" Diameter Holes are required for Each Towel Bar  
Maximum Recommended Slider Weight: 90 lbs.



5405 NW 102nd Ave, Sunrise FL 33351  
Phone: (813) 922-2309  
glazehardware.com

PROFESSIONAL GRADE

Cutting Instructions /  
Glass Sizing for  
DYNASTY SYSTEM  
Series Kit

**Single Sided Towel Bar:**

The (2) 24" center-to-center towel bars should be centered horizontally and positioned to your desired height vertically on the glass panel, with (2) 1/2" (12mm) diameter holes in each glass panel.

**QUICK METAL SIZE CUTTING FORMULA:**

Head Track = Top Overall Width Measurement Less 1/2" (12 mm)

**QUICK GLASS SIZE FORMULA TO DETERMINE**

NET WIDTH AND HEIGHTS

Single Glass Panel Widths = Overall Opening Width Divided by 2, Add 1"

Single Glass Panel Height = Overall Height Minus 3/8"

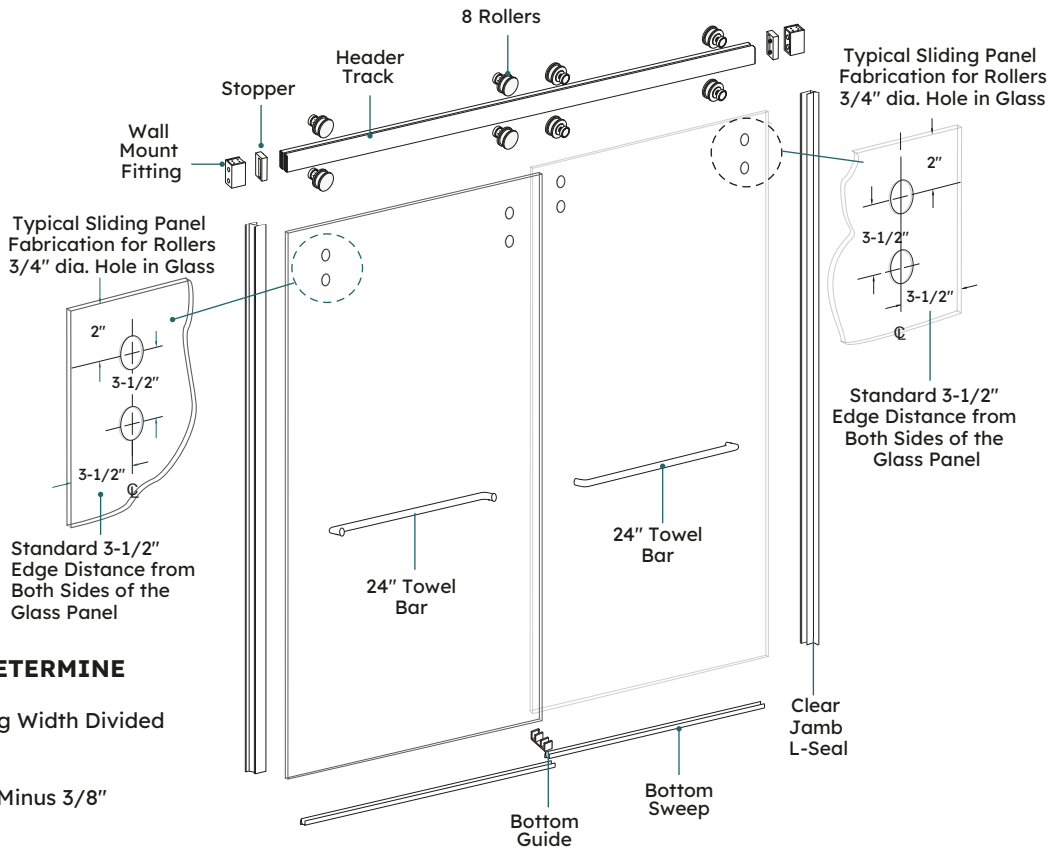

ALL KITS INCLUDE THE FOLLOWING COMPONENTS

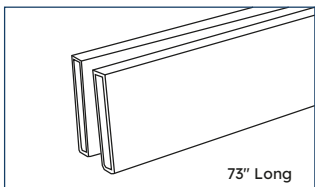

Header Track (Qty. 1)

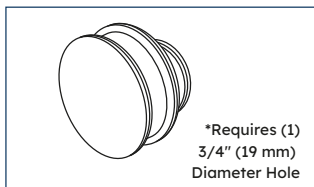

Glass Rollers (Qty. 8)

\*Requires (1) 3/4" (19 mm) Diameter Hole

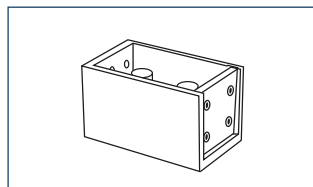

Wall Mount Fitting (Qty. 2)

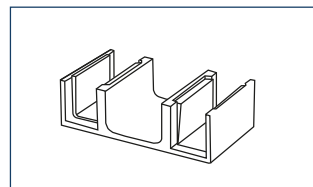

Bottom Guide

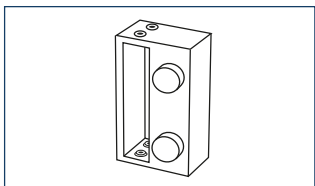

Sliding Panel Stopper (Qty. 2)

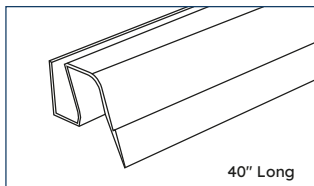

Bottom Sweep with Drip Rail (Qty. 2)

40" Long

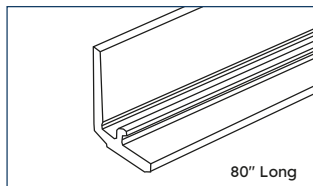

Jamb L-Seal (Qty. 2)

80" Long

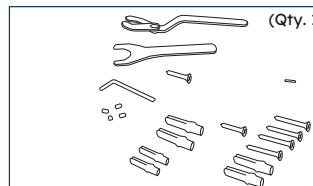

Tool Kit/Anchors (Qty. 1)

(Qty. 1)

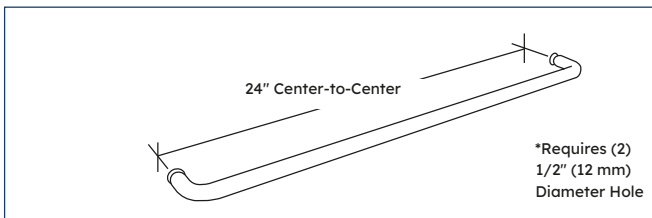

24" (610 mm) Single Sided Towel Bars (Qty. 2)

\*Requires (2) 1/2" (12 mm) Diameter Hole

24" Center-to-Center

## Frameless Sliding Shower System for Tub/Shower

Clean and remove any dirt or grime from your shower sill and wall areas where the new unit will be installed. **Carefully read these instructions completely and inventory all parts before starting installation.**

STEP  
1

### Head Track Preparation (Item # DYNA-SYSTEM)

Determine the height of your shower unit and measure the overall distance between the walls of your shower tub or tile surfaces. Subtract 1/2" and cut the Head Track to length. The Header Track is manufactured from stainless steel metal, a special saw blade should be used for proper cutting. Test fit the head track with the wall mount fittings installed on the ends to make sure it fits nicely between the walls.

**Important Note:** Make sure to Pre-load the (2) Sliding Panel Stoppers Fittings onto the Head Track.

STEP  
2

### Header Track and Wall Mount Fitting Installation (Item # DYNA-SYSTEM and Dynasty System)

Determine your shower door location on the sill or curb, typically its centered on the curb. Using a laser level and some securing tape mark the overall height of your shower unit then measure down 4-7/8" marking the location of the bottom of the wall mounted fitting. Proceed with marking and drilling the tile, (2 holes on each side) and installing the wall mounting fittings. **Note:** Wall mount screws and plastic plug anchors are included with kit. See diagram on page 2 for further information.

**Important Note:** Make sure the header track is installed level, the precision bearing glass rollers will force a sliding door panel to roll to one side if the header track is not installed level.

STEP  
3

### Head Track Installation (Item # DYNA-SYSTEM and Dynasty System)

Double check to insure you have pre-loaded the (2) Sliding Panel Stoppers onto each end of the Header Track as illustrated. Proceed with the installation of the Header Track by setting it into the installed wall mounted fittings and installing the top cover plates and set screws. If small adjustments are needed after the header track has been installed there is top and bottom set screw located at each wall mount fitting that can be adjusted.

STEP  
4

### Sliding Glass Panel Installation (Item # DYNA-SYSTEM)

Before hanging the sliding glass panels, proceed with installing just the (2) top glass rollers on your sliding glass panels. The glass rollers should be adjusted to the center "out of round" adjustment position. The bottom (2) glass rollers will be installed after the sliding panels are hung. Once that is complete move forward with hanging your sliding glass panels onto the Head Track using wood shims and allowing for a 3/8" bottom clearance. Once installed carefully remove the wood shims and test the sliding panel movement and adjust as needed. Once the adjustments are made to the glass rollers move forward with installing the (2) bottom glass rollers securing the sliding unit to the header track.

**Important Note:** Make sure you have adjusted and tightened the stoppers installed on the head track to your desired sliding range.

STEP  
5

### Bottom Floor Guide (Item # DYNA-SYSTEM)

Once the sliding glass panels have been installed and adjusted proceed with installing the bottom Floor Guide at the 1" glass panel overlap location. The floor guide comes with (2) attachment screws for proper securing. The sliding glass panels will need to be removed for this process. **Note:** Be sure to waterproof any hole's drill at the sill with an approved FHC silicone sealant.

STEP  
6

### L-Shaped Jamb Seal Polycarbonate and Bottom Sweeps (Item # DYNA-SYSTEM)

The FHC L-Shaped Polycarbonate Jamb Seal comes with Very Hi-Bond tape pre-applied for easy installation. Just remove the Very Hi-Bond tape backing and install aligning the "hub" on the seal with the glass edge. The nub will act as a bumper for the glass. Lastly, cut to size and install the provided bottom door sweep/drip rails.

STEP  
7

### Towel Bar Installation (Item # DYNA-SYSTEM)

The included single sided towel bars should be installed along with any optional knobs, handles, or hardware at this time. Caulk any areas that need additional sealing, clean and your installation is complete.

# Elevation Diagram

