

# INSTALLATION INSTRUCTIONS

## GLAZE ELITE SYSTEM SERIES ELI-SYSTEM SLIDING DOOR KIT.

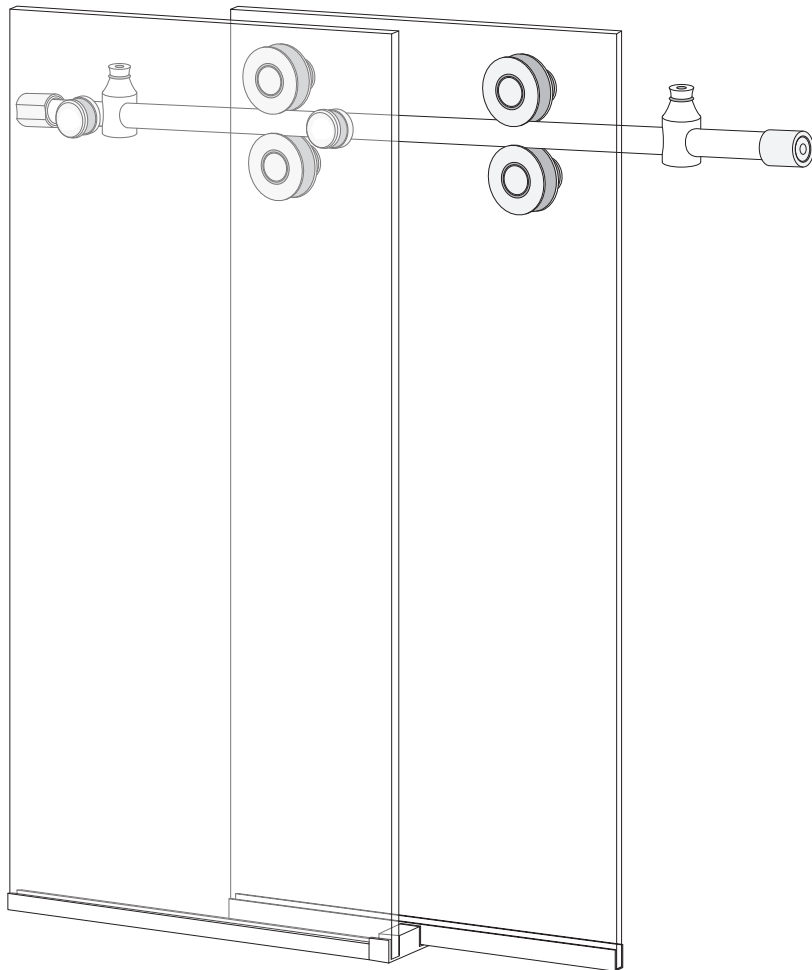

NOTE: Glass and U-Channels not included.



7860 W Commercial Blvd #757, Lauderhill, FL 33351  
Phone: (813) 922-2309  
[glazehardware.com](http://glazehardware.com)

11M0409\_11-16-19

# **ORDER OF ASSEMBLY AND INSTALLATION**

PARTS LIST .....	3
SPECIFICATIONS .....	3
GLASS FABRICATION .....	4
SLIDING DOOR PREPARATION .....	5
Unpack Rollers .....	5
Install Top Rollers .....	5
Install Bottom Sweep .....	5
SITE PREPARATION .....	6
Mark Location for Header Support Bar .....	6
FRAME FABRICATION .....	6
Prepare Header Bar: Opening Width Greater Than 53-1/4" .....	6
Prepare Header Bar: Opening Width Less Than 53-1/4" .....	6
FRAME INSTALLATION .....	7 - 10
Mount Track Holder Fittings .....	7
Install Stopper .....	7
Install Header .....	7
Bottom Guide Mounting Options and U-Channel Preparation (Optional) .....	8
Unpack and Prepare Bottom Door Guide .....	8
Install Fixed Panel Curb Mounts .....	8
Install Fixed Panels .....	9
Place Bottom Door Guide .....	9
Install Bottom Door Guide .....	10
SLIDING DOOR INSTALLATION .....	10
Hang Sliding Door .....	10
Install Bottom Rollers .....	10
FINISHING .....	11
Adjust Stopper Position .....	11
Install L-Seal .....	11

**IMPORTANT: READ THIS MANUAL THOROUGHLY BEFORE BEGINNING INSTALLATION.**

# PARTS LIST

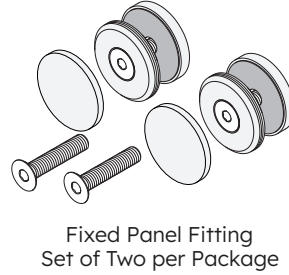
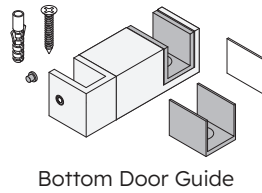
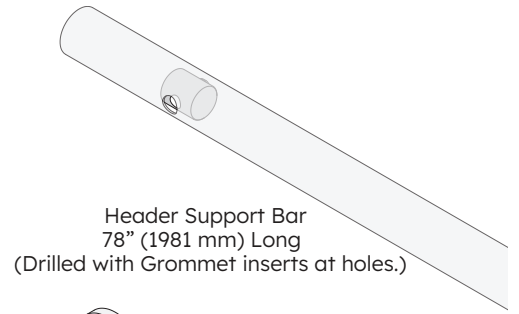
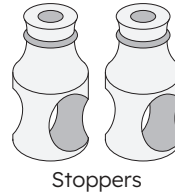
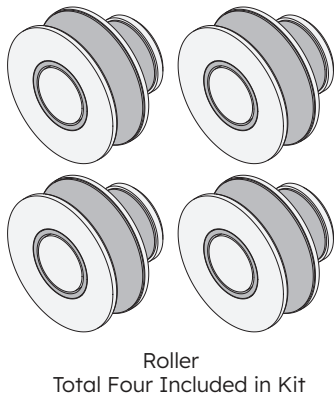

# SPECIFICATIONS

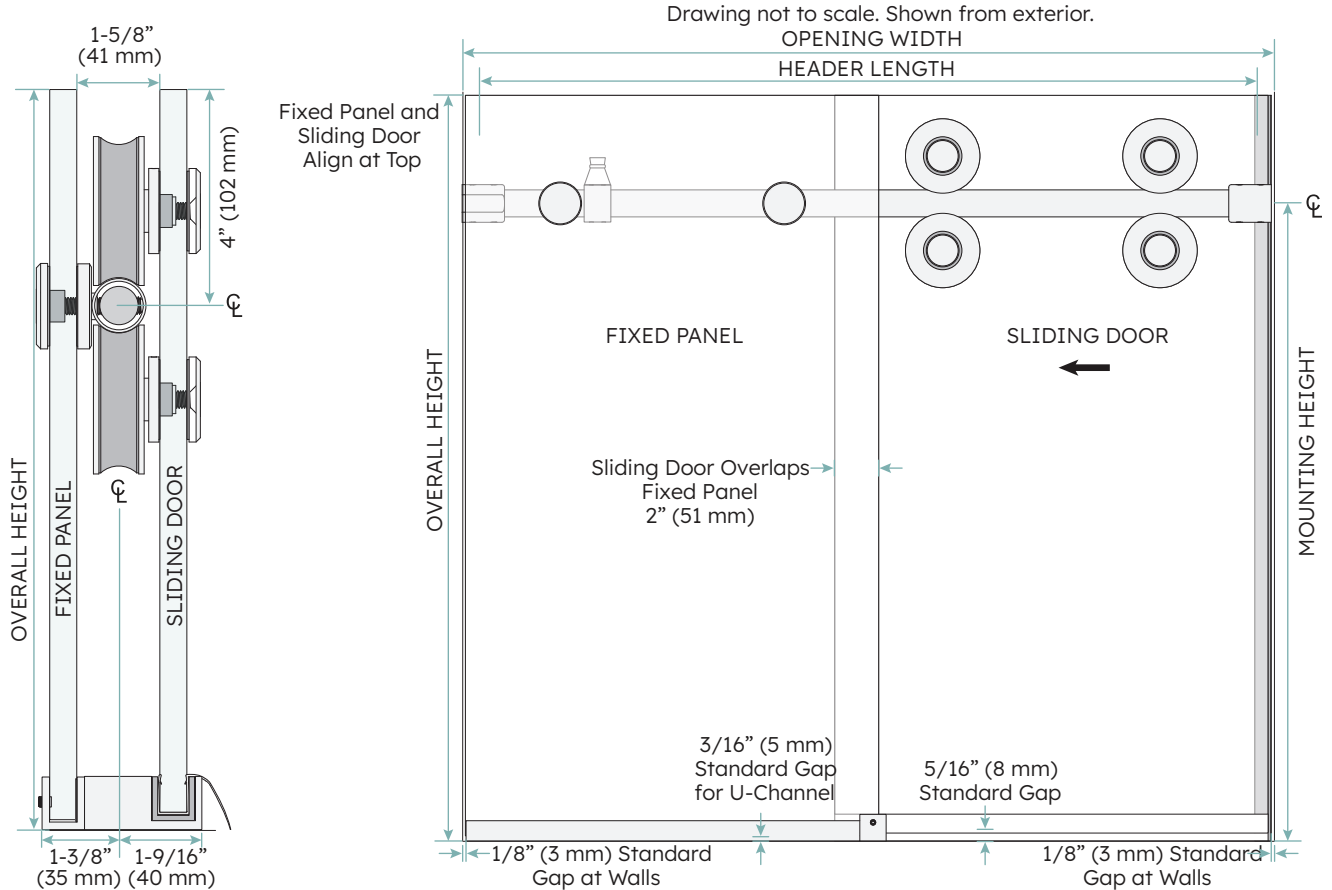

# GLASS FABRICATION

Use 3/8" or 1/2" (10 or 12 mm) Tempered Glass only. Do not use Laminated Glass.

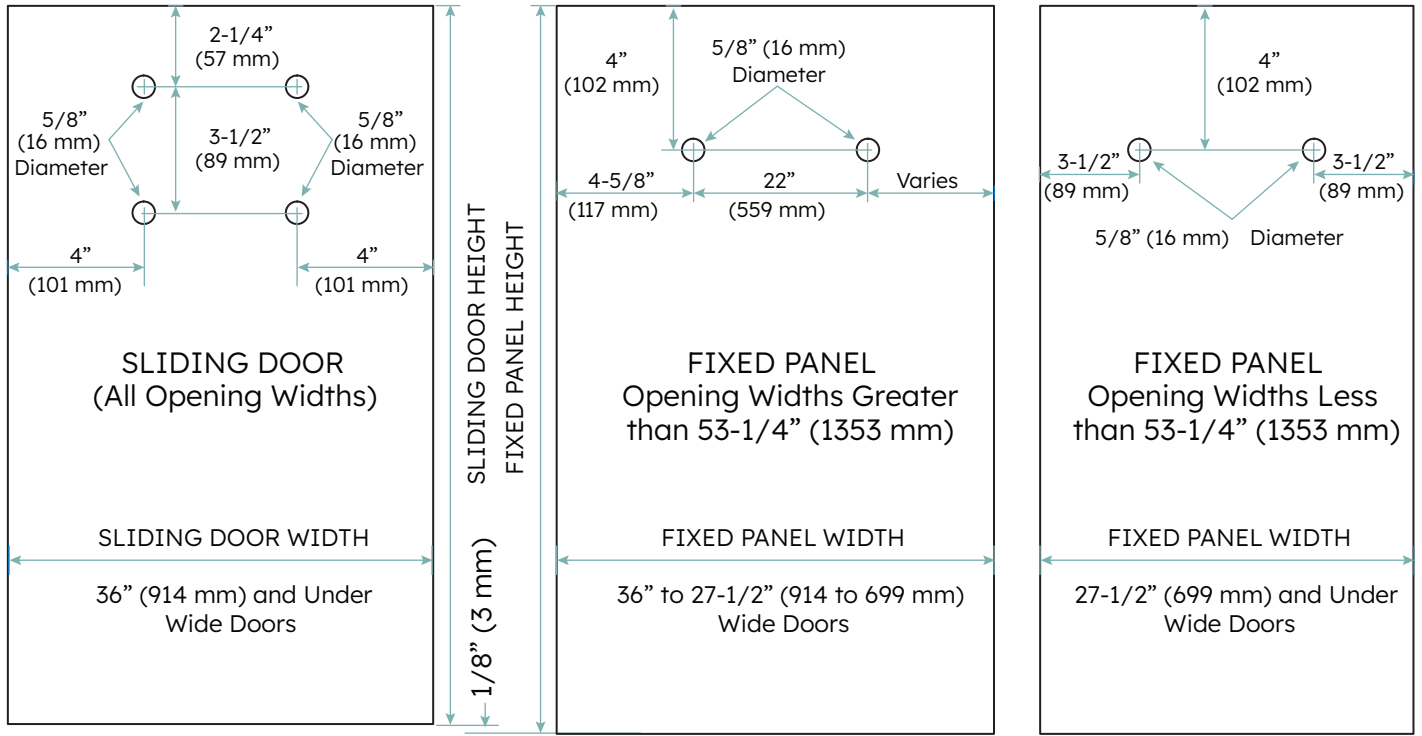

NOTE: For Opening Widths less than 53-1/4" we recommend moving the holes for the Fixed Panel closer to the edge of the glass as shown above.

## FIXED PANEL AND SLIDING DOOR HEIGHTS

FIXED PANEL: Overall Height minus 3/16" (5 mm)

SLIDING DOOR: Overall Height minus 5/16" (8 mm)

## FIXED PANEL AND SLIDING DOOR WIDTHS

2 EVEN PANELS: Overall Width divided by 2, plus 7/8" (22 mm). NOTE: Fixed Glass Fabrication changes for Openings less than 53-1/4".

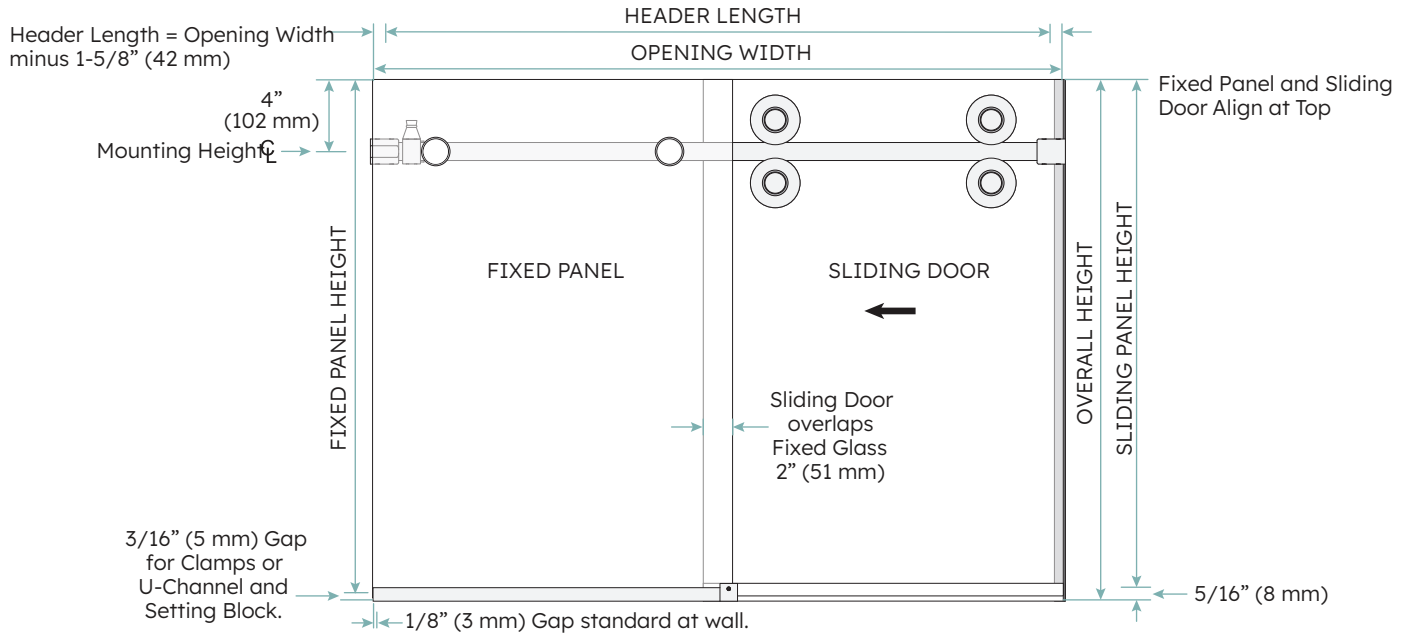

NOTE: Drawings not shown to scale. Track is cut 1-5/8" (42 mm) less than Opening Width and centered in opening. Overall Height is height from curb/floor to top of glass. Drawings shown from interior.

# SLIDING DOOR PREPARATION

## Unpack Rollers

- 1 Unpack and partially disassemble two sets of Rollers.

NOTE: Rollers shipped assembled.  
5 mm Allen Wrench included.

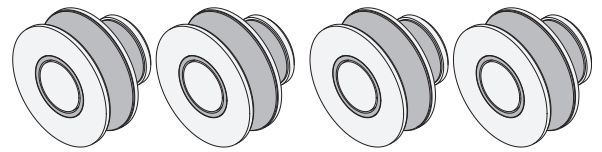

Rollers (Four Each) Exterior View

## Install Top Rollers

- 2 Adjust wheel height.
- 3 Install Top Rollers on Sliding Door.

NOTE: Lower Rollers are installed  
after door is hung. See Page 10.

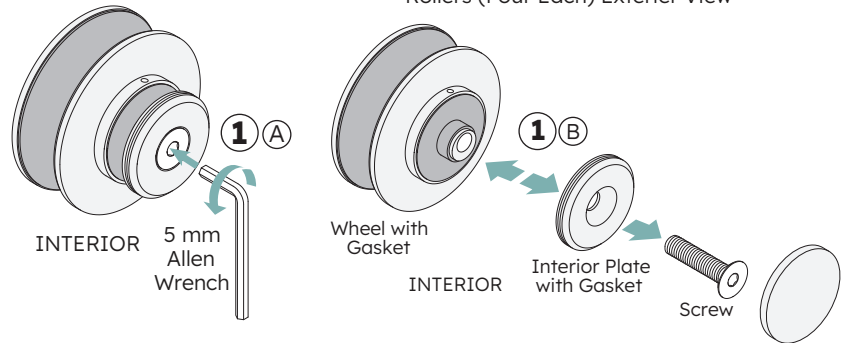

## Install Bottom Sweep

- 4 Cut Bottom Sweeps to door width and fit on the bottom of door.

NOTE: Select one of two sizes of included Sweeps.

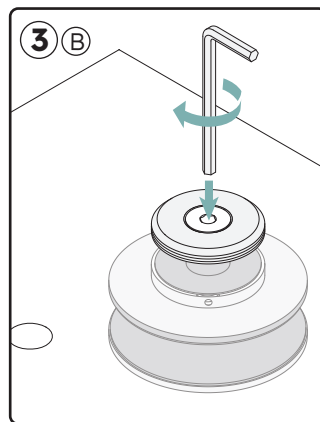
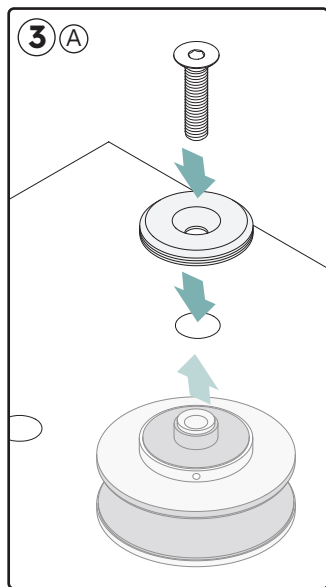

Install Top Rollers.  
Lower Rollers installed  
after door is hung.

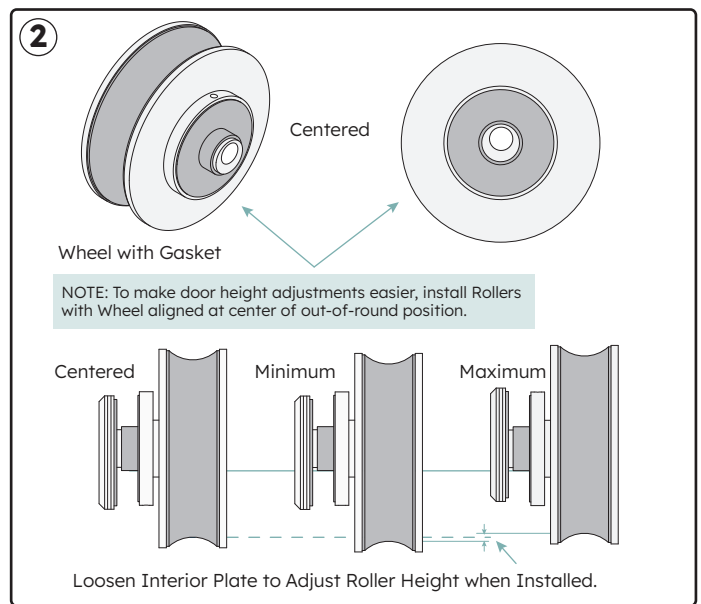

- 3 B Tighten with Included 5 mm Allen Wrench.

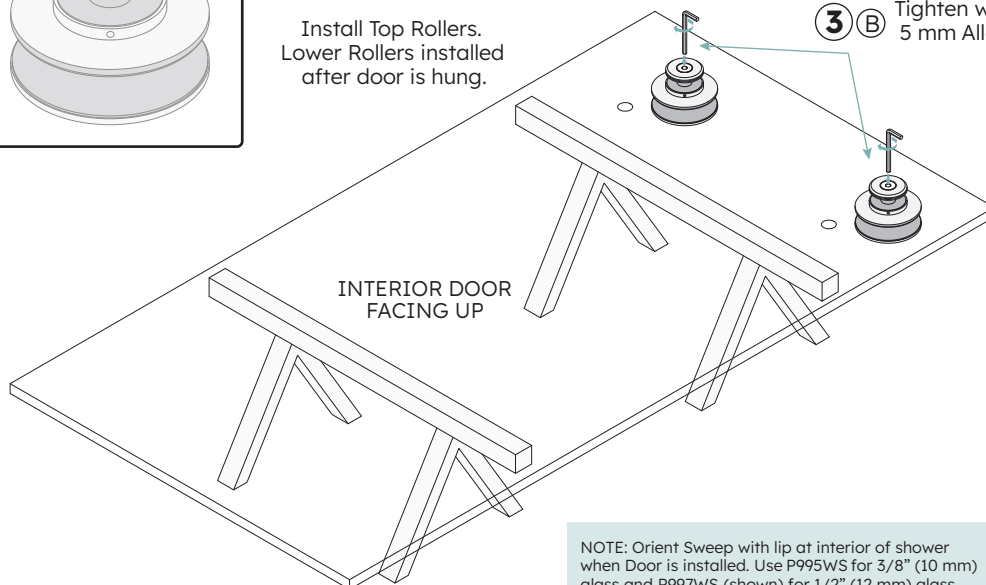

NOTE: Orient Sweep with lip at interior of shower  
when Door is installed. Use P995WS for 3/8" (10 mm)  
glass and P997WS (shown) for 1/2" (12 mm) glass.

# SITE PREPARATION

## Mark Location for Header Support Bar

- 1 Mark and drill holes for Header Support Bar.

NOTE: Header Support Bar is not centered between Sliding Door and Fixed Panel. When installing Fixed Panel to exterior (traditional placement) allow at least 1-3/8" (35 mm) from edge to install Bottom Guide.

- 2 Measure opening width at mounting points.

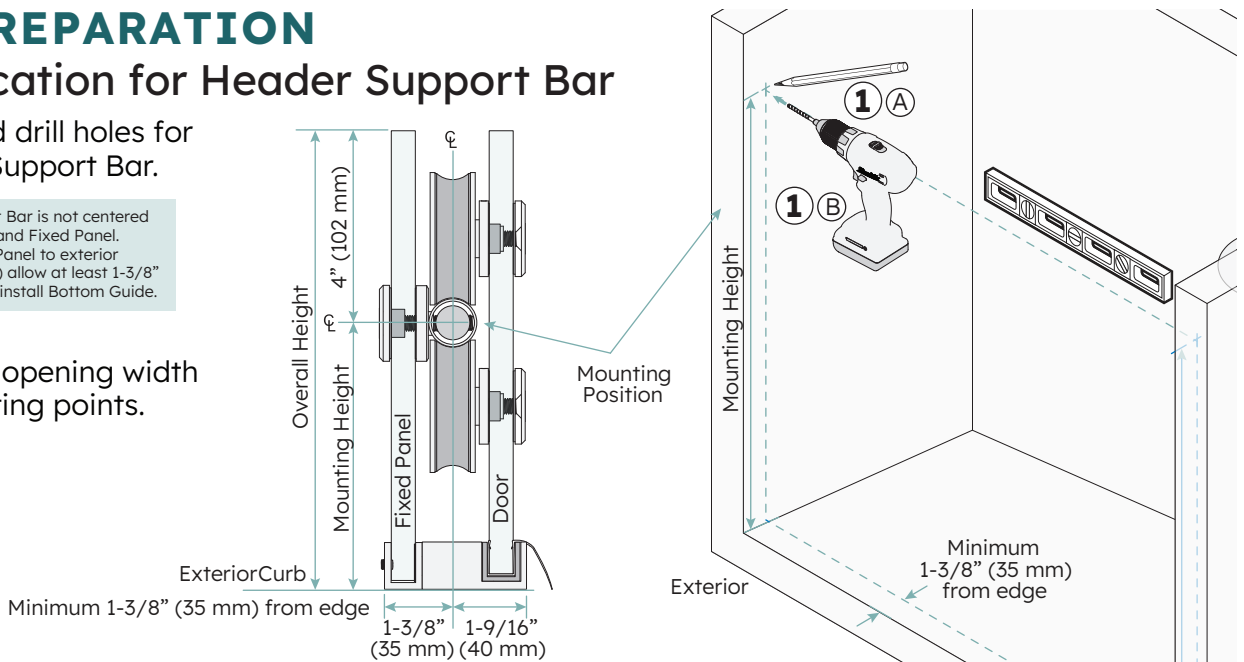

# FRAME FABRICATION

## Prepare Header Bar: Opening Width Greater Than 53-1/4"

- 3 Cut Header Bar from end without holes.

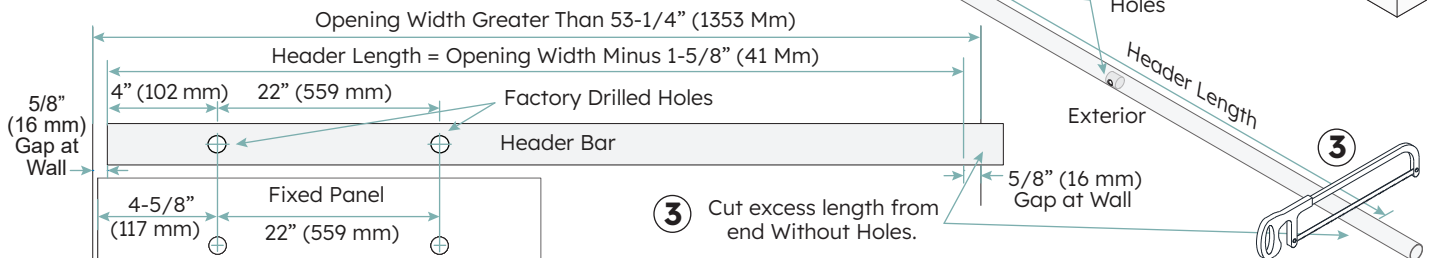

NOTE: Header Support Bar is cut 1-5/8" (41 mm) short from tight dimension and centered in opening. NOTE: Header Bar is made of stainless steel. Use hacksaw or special cutting tool.

## Prepare Header Bar: Opening Width Less Than 53-1/4"

- 4 Cut excess length from Header Bar from both ends.

NOTE: Remove Grommet at first hole before cutting. Header Bar is made of stainless steel. Use hacksaw or special cutting tool.

- 5 Drill second hole for Fixed Panel Fitting and reinstall Grommet.

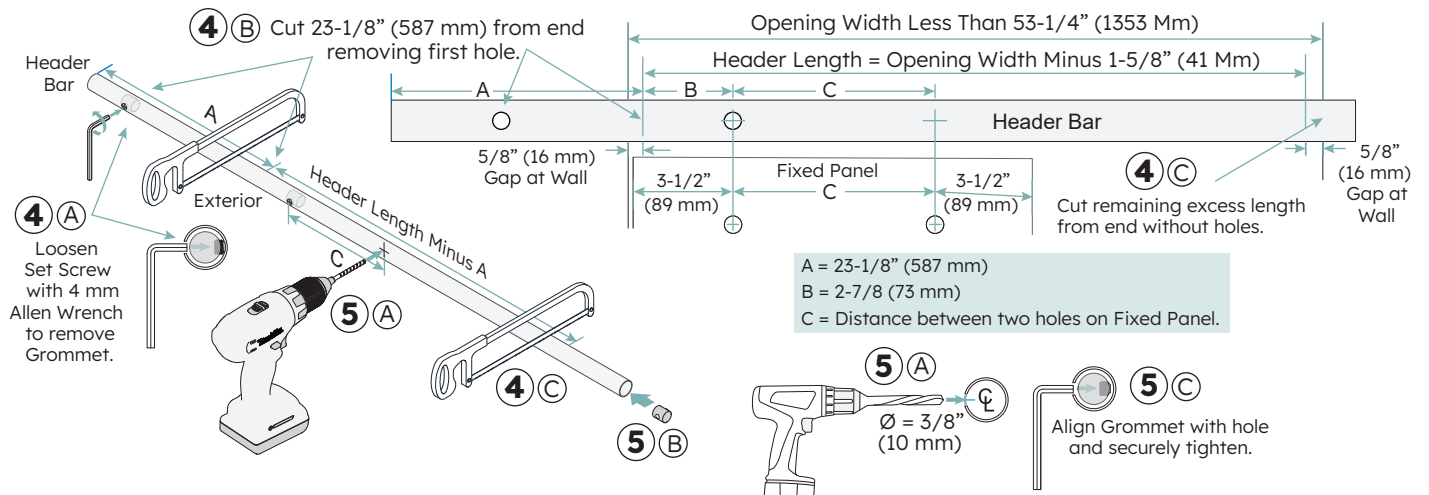

# FRAME INSTALLATION

## Mount Track Holder Fittings

- 1 (A) Unpack Track Holder Fittings. Loosen Set Screws and remove Mounting Blocks.
- 2 Fasten Mounting Blocks to wall.

NOTE: Track Holder Fittings shown orientated for installation. Set Screws at end hold Base to Mounting Block while second Set Screws secure Base to Header when installed.

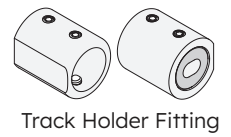

## Install Stopper

- 3 Unpack and loosen Set Screws on top and bottom of Stopper.

## Install Header

- 4 Slide Stopper and Track Holder Fittings onto Header.

NOTE: Orient Stopper with Rubber Bumpers facing center and Track Holder Fittings with rounded end facing center.

- 5 Align Header with Mounting Block. Slide Track Holder Fittings to wall and tighten Set Screws to secure.

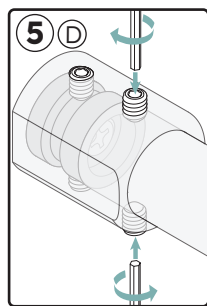
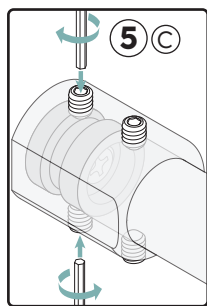
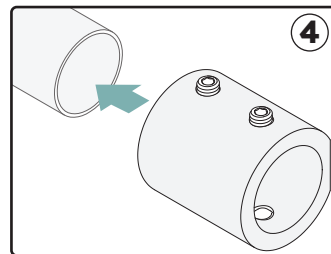
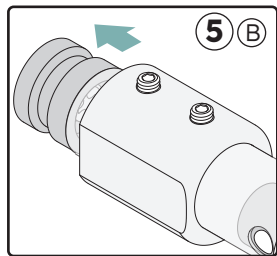
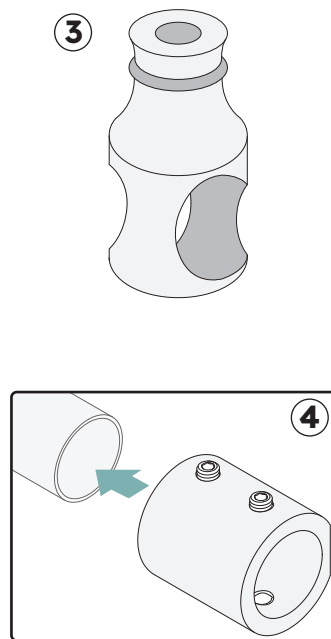
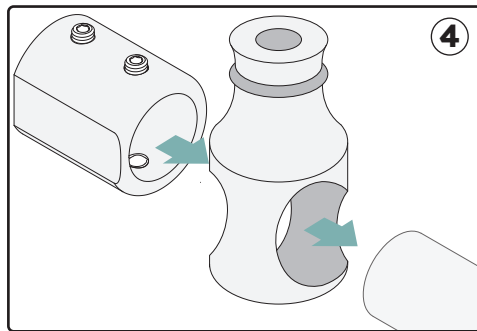
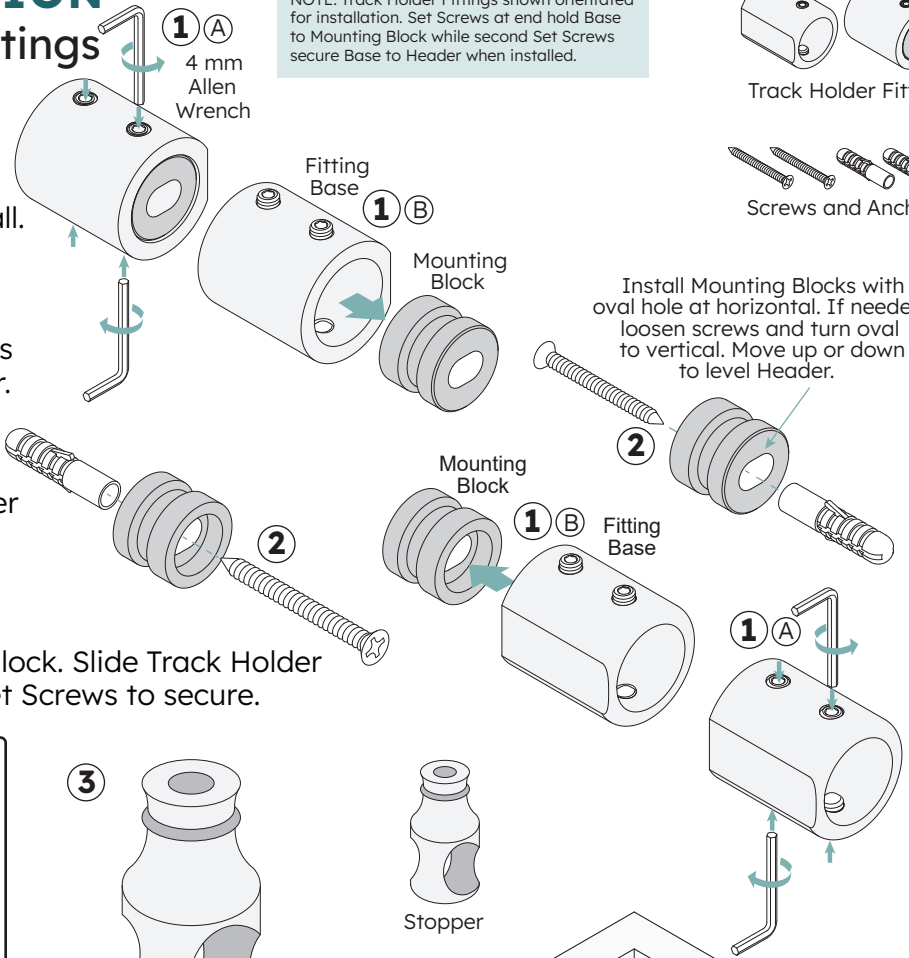

NOTE: Ensure Header is level. If not, loosen screws holding Mounting Blocks to adjust height.

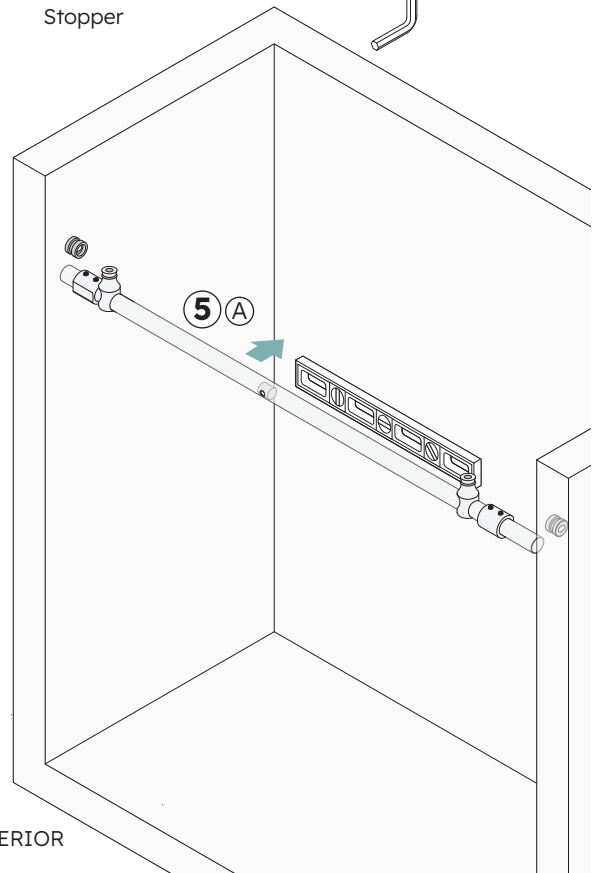

# FRAME INSTALLATION (CONTINUED)

## Bottom Guide Mounting Options and U-Channel Preparation (Optional)

NOTE: Fixed Panel may be fastened to curb with clamps. Use dimensions shown below to calculate length of U-Channel for each mounting option.

### 1 Determine Bottom Door Guide mounting option.

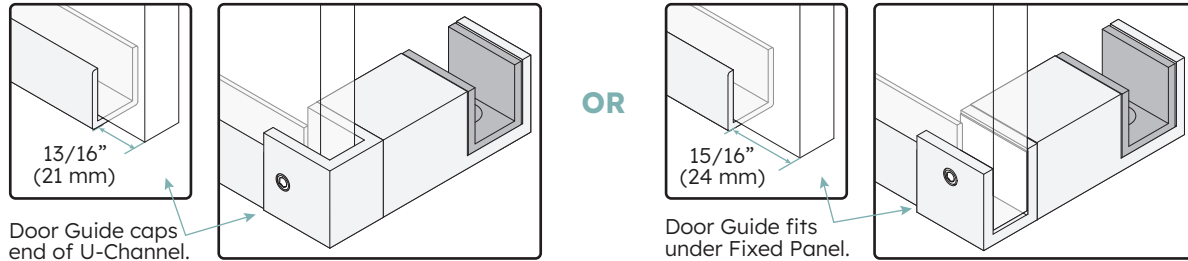

## Unpack and Prepare Bottom Door Guide

### 2 Unpack Bottom Door Guide. Rotate orientation if needed. (Optional)

NOTE: Door Guide shipped oriented to cap Fixed Panel on right. Loosen bottom Set Screw and rotate base to change orientation. Select smaller of two included inserts.

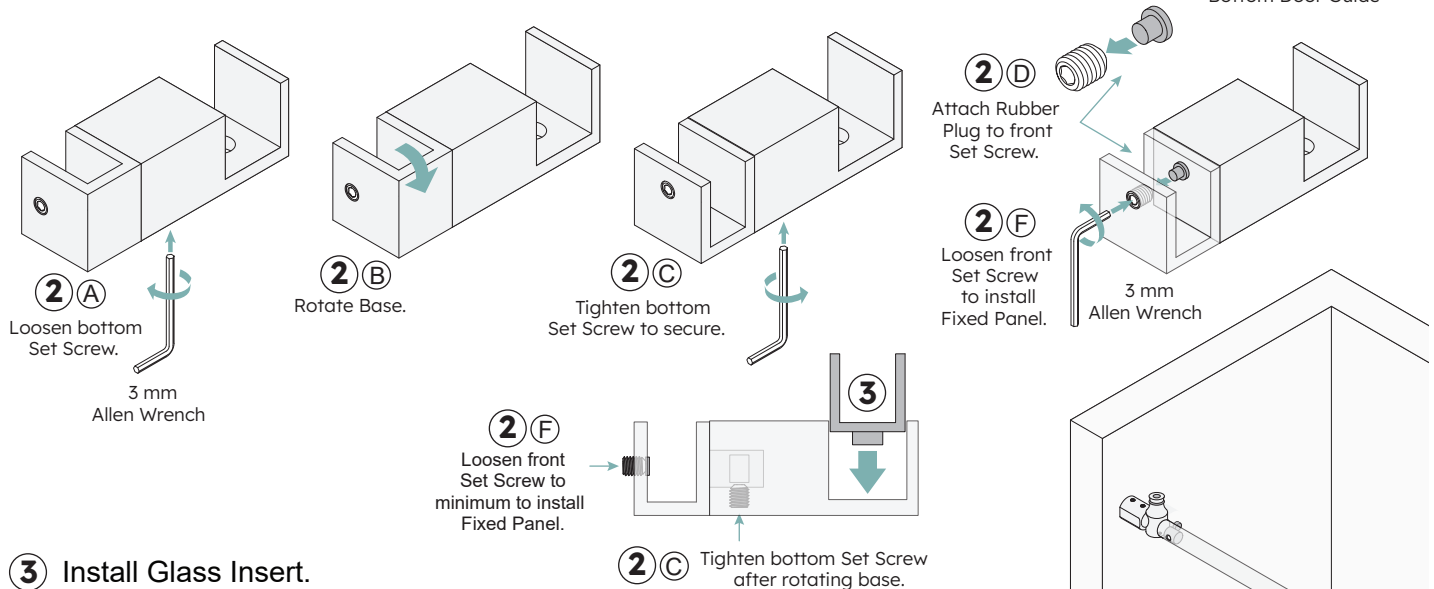

### 3 Install Glass Insert.

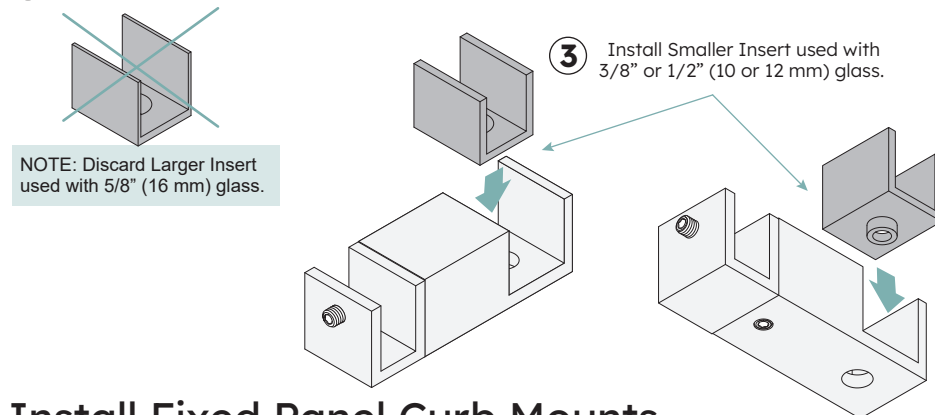

## Install Fixed Panel Curb Mounts

### 4 Mount Clamps or U-Channel on curb.

NOTE: Door Guide installed after Sliding Door is hung. Door Guide positioned under Fixed Panel shown in installation in this manual.

NOTE: U-Channel not included. Shown as example only.

EXTERIOR

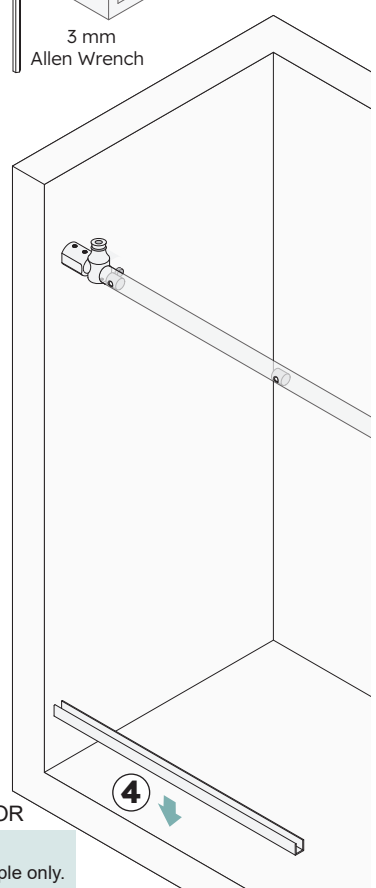

# FRAME INSTALLATION (CONTINUED)

## Install Fixed Panels

- 1 Unpack and disassemble Fixed Panel Fittings.
- 2 Attach Fixed Panel Fittings to Fixed Panel.
- 3 Align Fittings with Grommets in Header Bar. Securely fasten.

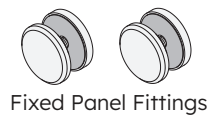
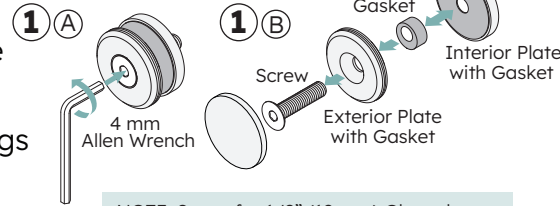

NOTE: Screw for 1/2" (12 mm) Glass shown. Shorter screw used for 3/8" (10 mm) Glass.

NOTE: If Grommets are not centered, loosen Track Holder Set Screws and rotate Header Bar.

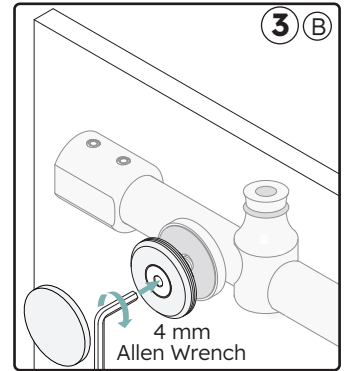
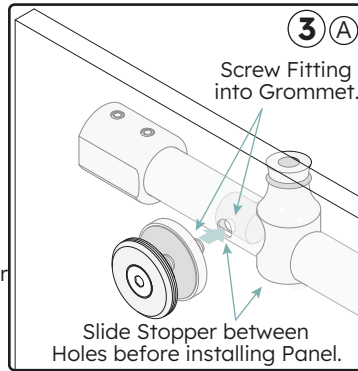
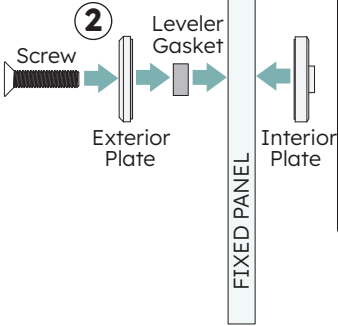
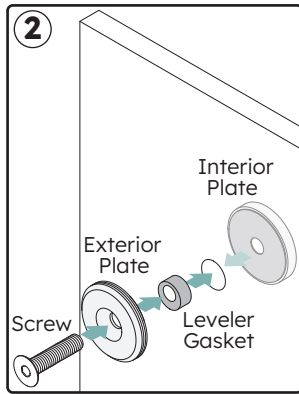

## Place Bottom Door Guide

- 4 Hang Sliding Door and carefully slide back and forth to check height.

NOTE: See Page 5 to Prepare Door before hanging and to adjust Roller height if needed.

- 5 Place Door Guide to engage with Sliding Door. Close Door, adjust Guide position and outline.

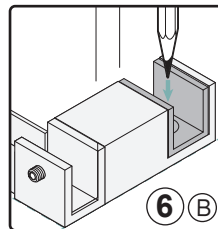
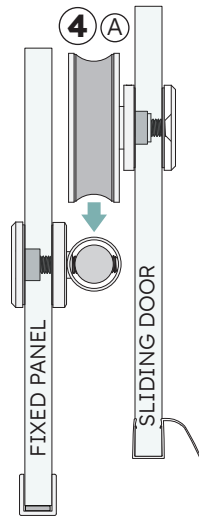
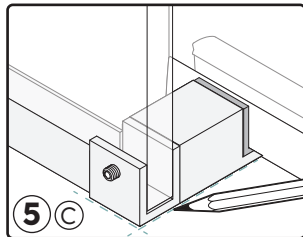

- 6 Remove Door to mark hole.
- 7 Remove Guide. Drill hole and insert anchor.

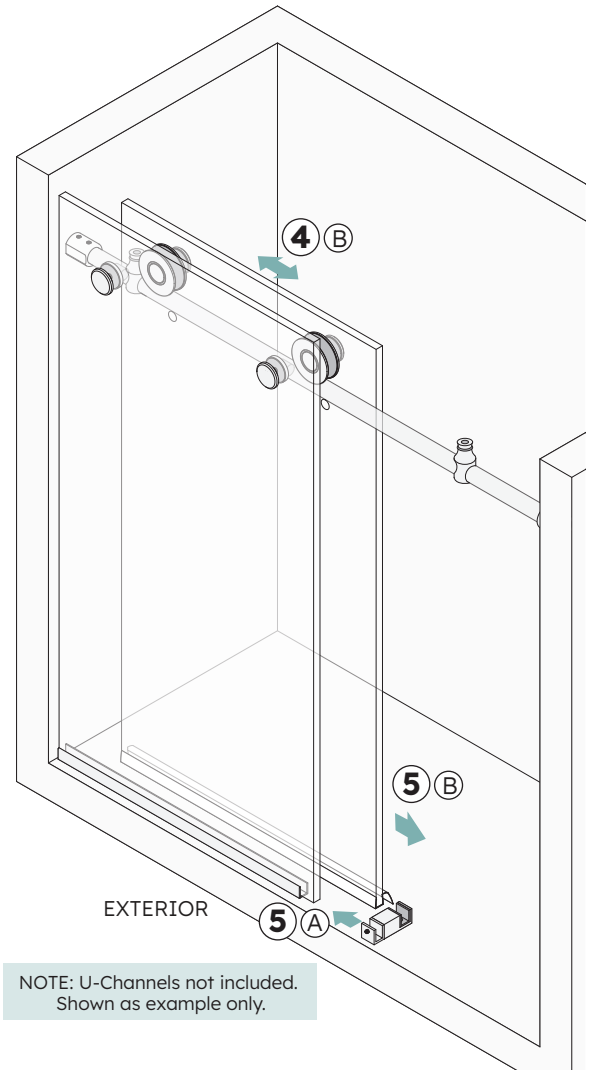
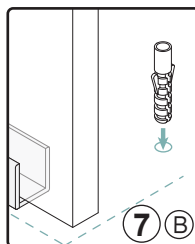
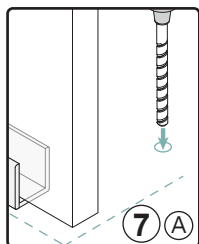

NOTE: U-Channels not included. Shown as example only.

# FRAME INSTALLATION (CONTINUED)

## Install Bottom Door Guide

1 Fasten Bottom Door Guide and tighten Set Screw at Fixed Panel.

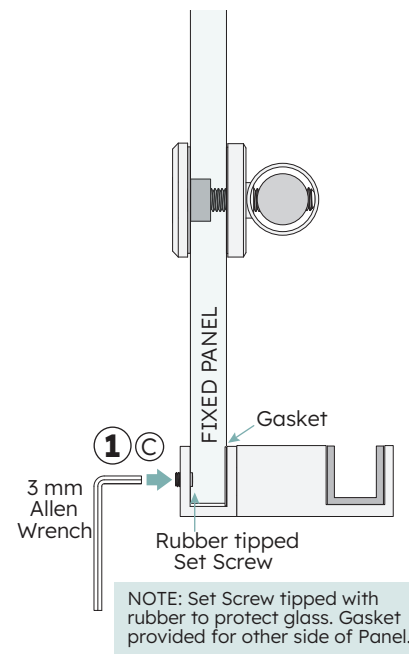
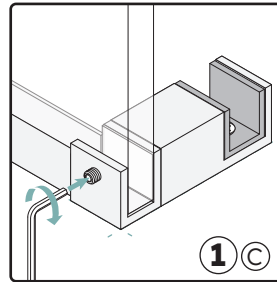
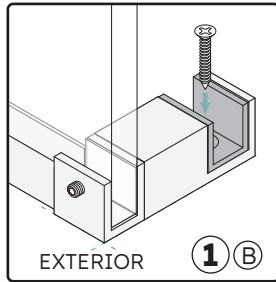
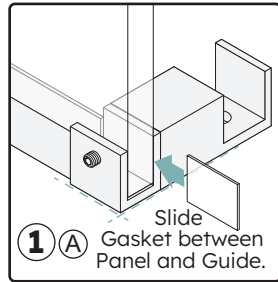

## SLIDING DOOR INSTALLATION

### Hang Sliding Door

2 Hang Sliding Door placing Glass inside Bottom Guide.

### Install Bottom Rollers

3 Prepare and install Bottom Rollers.

NOTE: See Page 5 before installing Rollers.

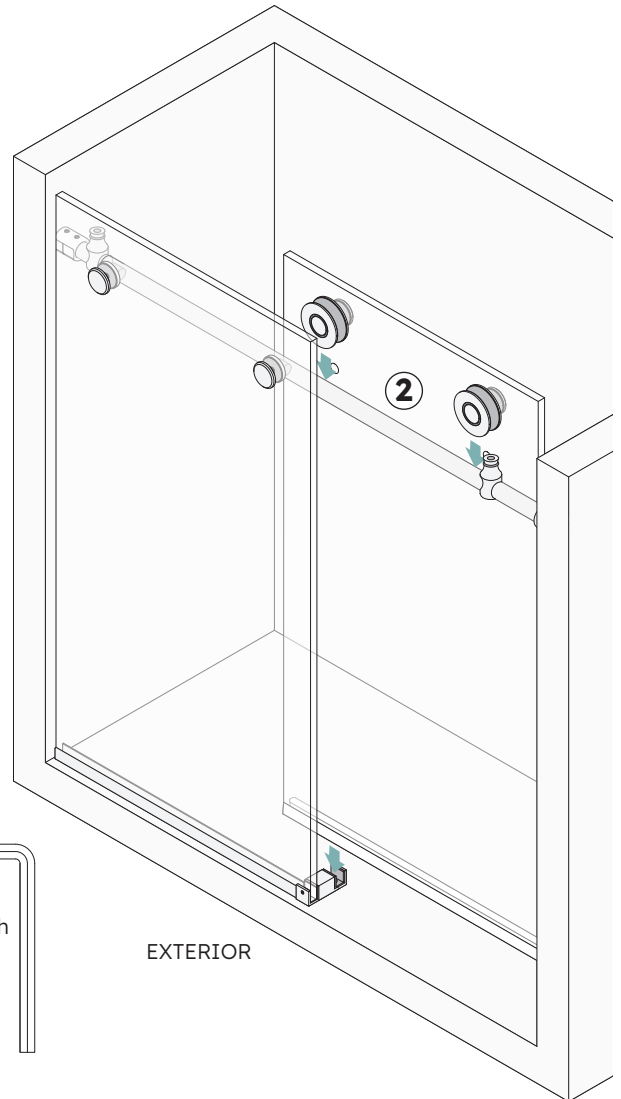
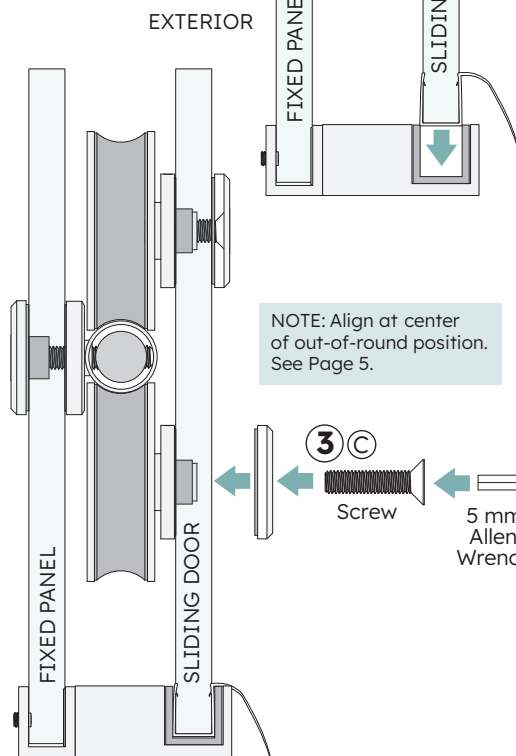
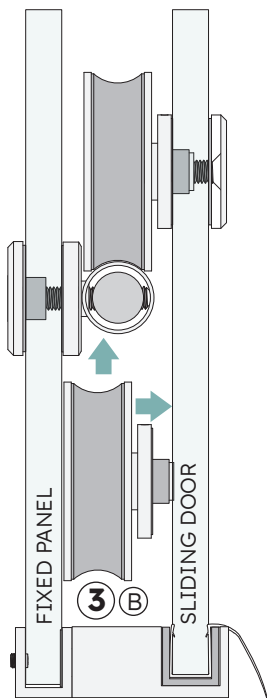
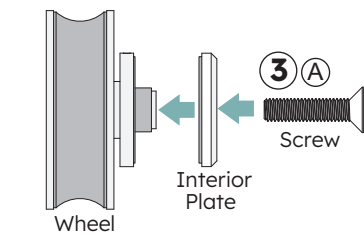

# FINISHING

## Adjust Stopper Position

- 1 Position Door Stop and secure.

## Install L-Seal

- 2 Cut and install L-Seal.

NOTE: Temporarily attach L-Seal to Sliding Door. Use as guide for final position.

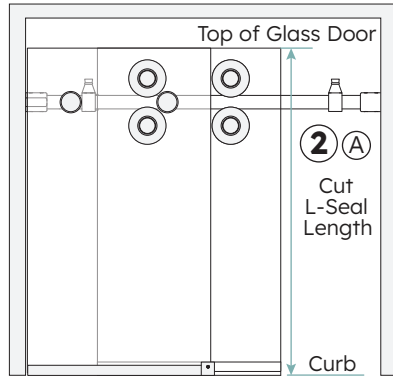
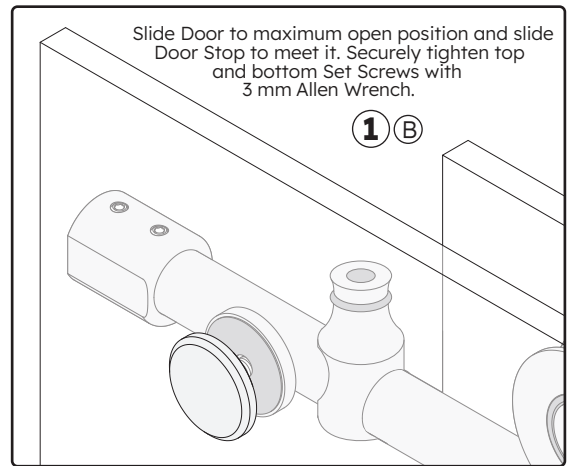

VIEW FROM EXTERIOR

