

INSTALLATION INSTRUCTIONS

GLAZE EMPRESS SYSTEM SERIES EMPRESS SLIDING DOOR KIT.



Phone: (813) 922-2309
glazehardware.com

SLIDING SYSTEM TEMPLATE

Please keep this manual and the product code number for future reference and to order replacement parts if necessary

GENERAL INSTRUCTIONS

- Please read this manual carefully and thoroughly before proceeding.
- For your safety, it is recommended that you wear safety glasses at all times during installation.

INSTALLATION OVER CERAMIC TILES

- If you are installing the shower door over ceramic tiles, make sure that the tiles lay completely under the wall jamb.
- Use mildew resistant silicone to seal the gaps where the ceramic tiles meet the fixed panel.

NOTICE

- Caulking is not required inside the shower, unless otherwise stated.
- Some models are equipped with clear sealing gaskets.

CARE FOR YOUR SHOWER DOOR









- Do not use scouring powder pads or sharp instruments on metal pieces or glass panels.
- To keep the panels and metal parts looking new, occasionally wipe them down with a mild soap diluted in water.
- We recommend wiping the glass panels with a squeegee after each use.

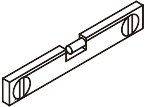

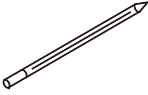
2 PEOPLE REQUIRED

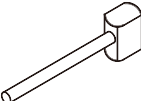
Product specifications are subject to change without notice.

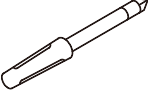
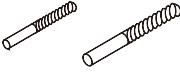
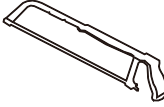
TOOLS REQUIRED

 SPIRIT LEVEL	 POWER DRILL	 PENCIL	 SILICONE	 MALLET
 TAPE MEASURE	 SCREW DRIVER	 6mm & 8mm (1/4" & 5/16") DRILL BITS	 HACKSAW	 SAFETY GLASSES

* Use a 6mm (1/4") drill bit for ceramic when drilling into ceramic tiles.

CHOOSE A CONFIGURATION

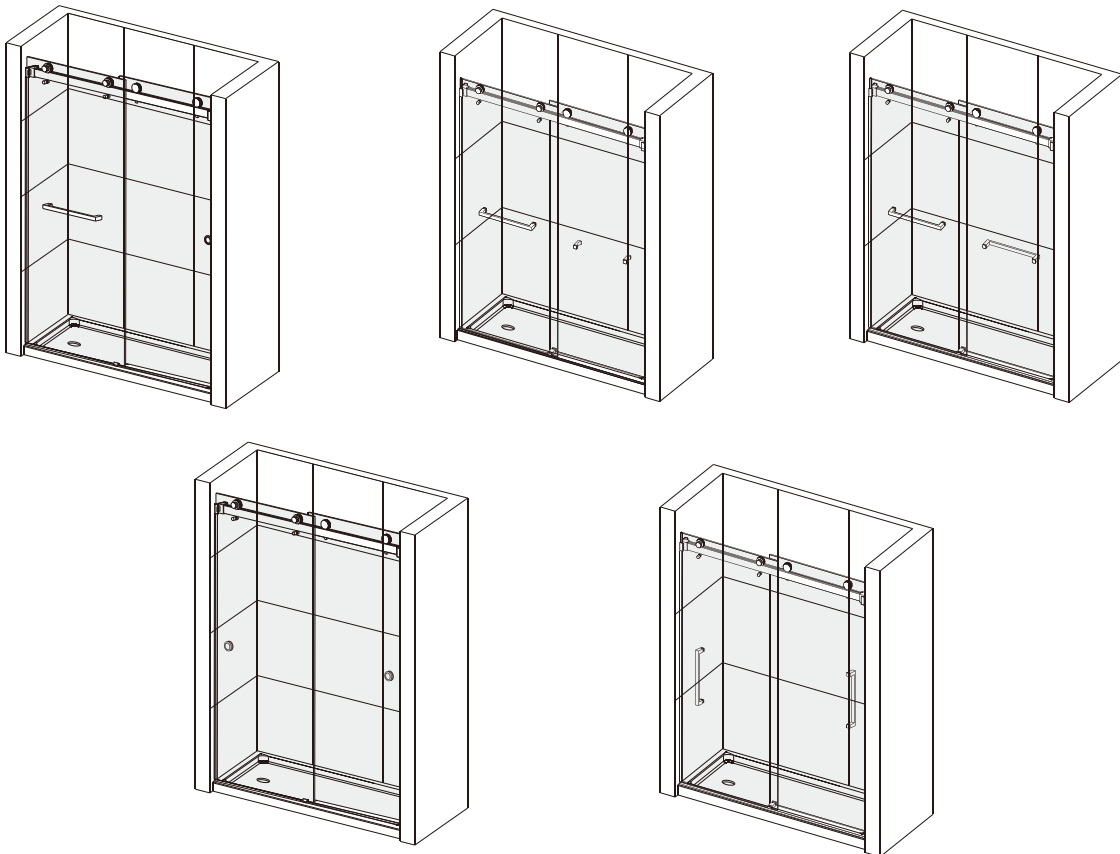



*We offer our product in various sizes, with hardware available in a range of finishes. If clear glass isn't your preference, we also provide Acid Etch (frosted) glass, Glass door handles you can choose from, offering both a stylish appearance and enhanced privacy for your shower door.

EMPRESS SLIDING DOOR KIT.

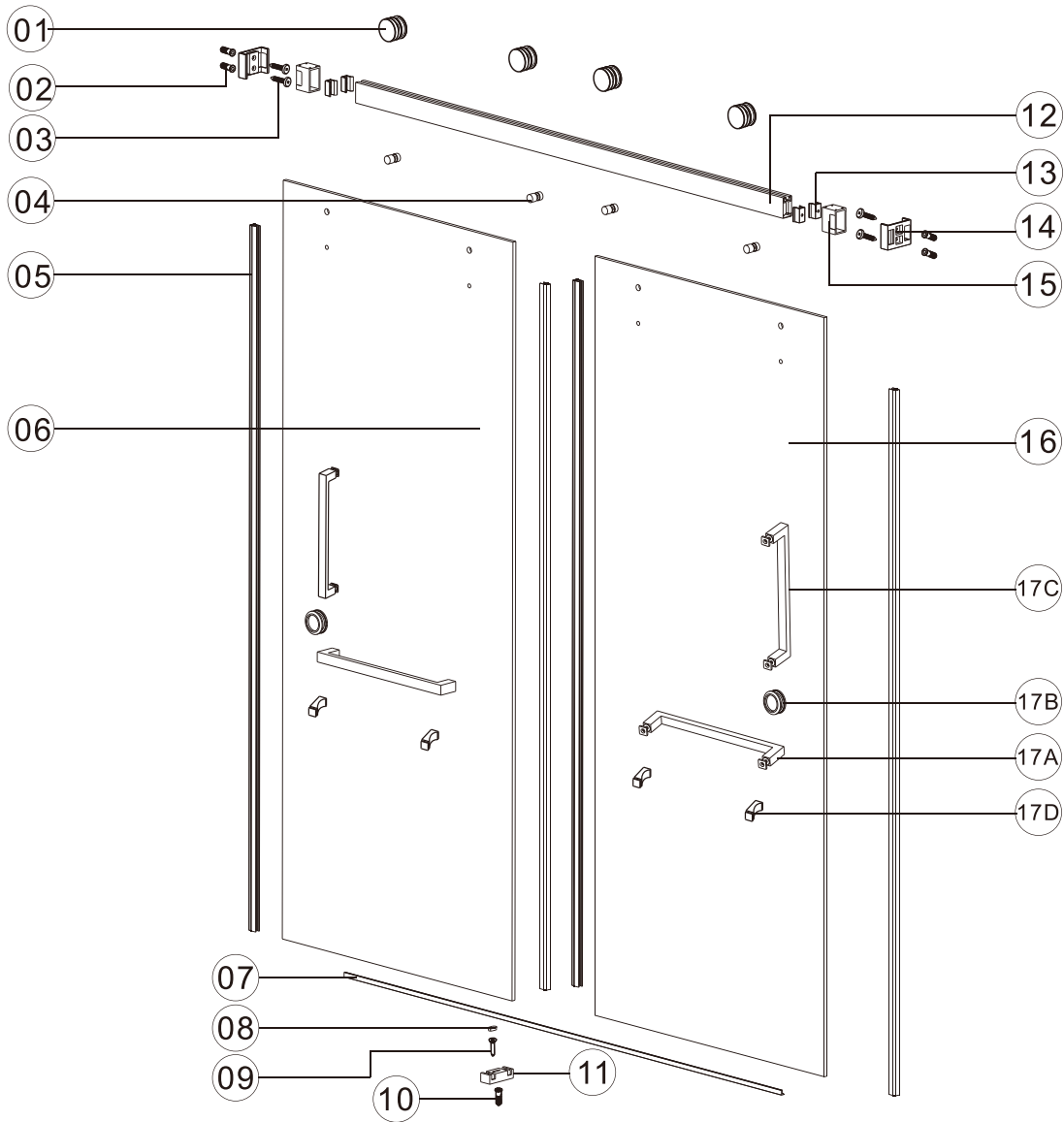

PARTS LIST



ITEM	PARTS	DIAGRAM	QTY	ITEM	PARTS	DIAGRAM	QTY
1	Ø60 Roller		4	11	Bottom guide		1
2	Wall anchor Ø8		4	12	Header bar		1
3	Screw St5x45		4	13	Rubber cushion		4
4	Anti-jump nail		4	14	Track holder		2
5	Plastic seal		4	15	Wall mount bracket		2
6	Sliding door		1	16	Sliding door		1
7	Threshold		1	17A	Towel bar		1
8	Bottom guide cover		1	17B	Finger pull		1
9	Screw St4x30		1	17C	Handle		1
10	Wall anchor Ø6		1	17D	Point handle		2

PARTS LIST



■ **SYRO-HED**
Aluminum Header Bar
Length: 48" - 98"

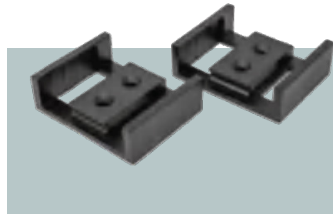

■ Track Holder
304 Stainless Steel



■ Wall Mount Bracket
304 Stainless Steel



■ **SYRO-ROL**
Roller - Diameter: 60mm
304 Stainless Steel

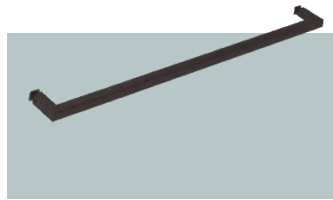

■ 20" Towel Bar
304 Stainless Steel



■ Rubber Cushion

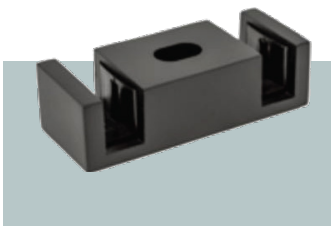

■ **SYRO-BO**
Bottom Guide
Length: 3"
316 Stainless Steel



■ Finger Pull
304 Stainless Steel



■ **SYRO-JU**
Anti-Jump Nail
304 Stainless Steel

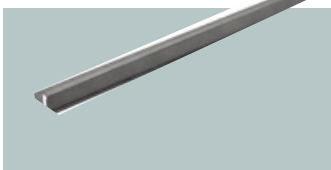

■ Aluminum Threshold

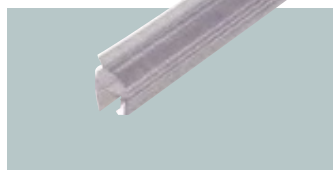

■ Glass-To-Wall Sealing Strip

SECTION DIAGRAM

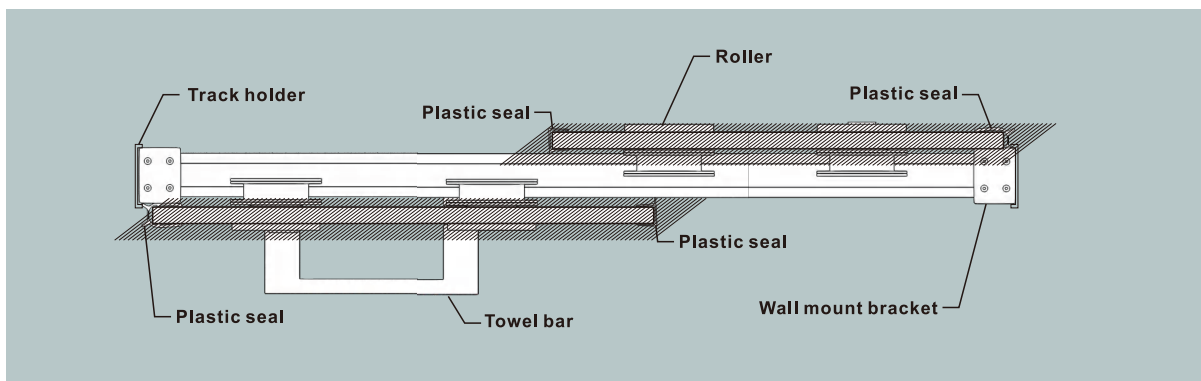
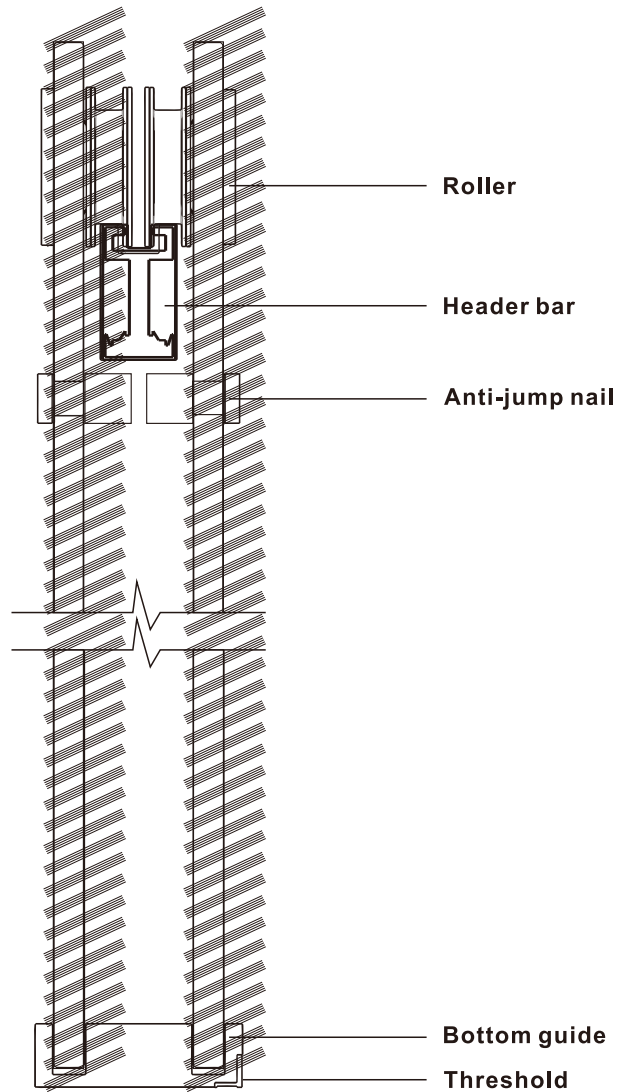

EMPRESS DRILLING GUIDE

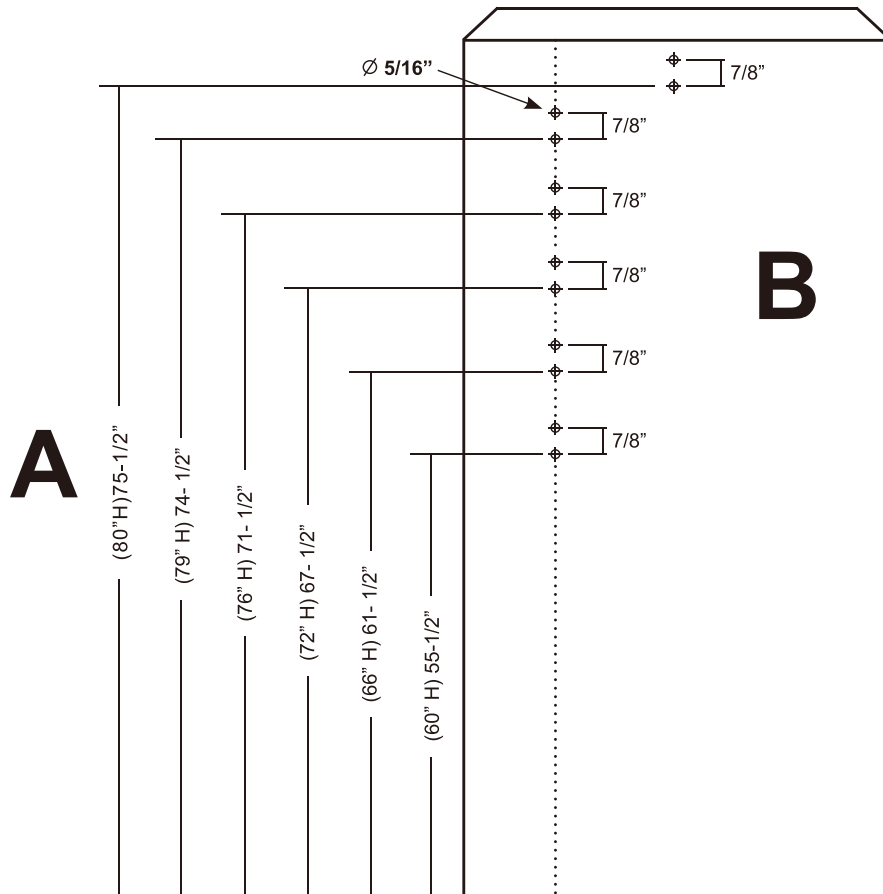

Product Height	A	B
60"(1524mm)	55 1/2"(1411mm)	7/8" (22mm)
66"(1676mm)	61 1/2"(1563mm)	
72"(1828mm)	67 1/2"(1716mm)	
76"(1930mm)	71 1/2"(1817mm)	
79"(2006mm)	74 1/2"(1894mm)	
80"(2032mm)	75 1/2"(1919mm)	

*A=Floor to First Hole

*Please contact your local dealer if the size is not listed.

ATTENTION

Please verify the measurements with a tape measure before drilling any holes in the wall.

STEP 1

Installation of upper horizontal header

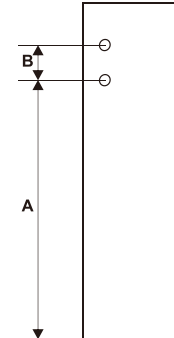
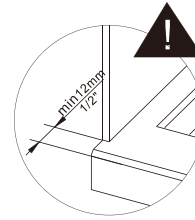
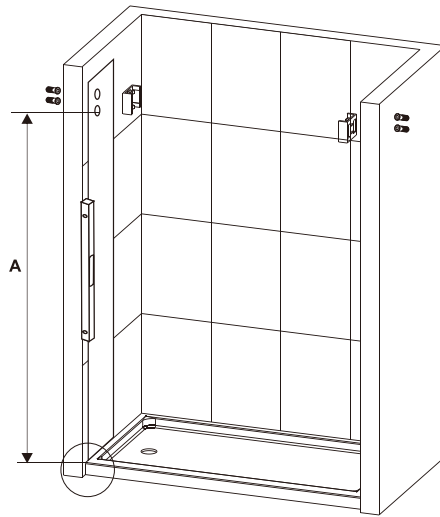

Product Height	A	B
60"(1524mm)	55 1/2"(1411mm)	7/8" (22mm)
66"(1676mm)	61 1/2"(1563mm)	
72"(1828mm)	67 1/2"(1716mm)	
76"(1930mm)	71 1/2"(1817mm)	
79"(2006mm)	74 1/2"(1894mm)	
80"(2032mm)	75 1/2"(1919mm)	

*A=product height-113mm(4 1/2")

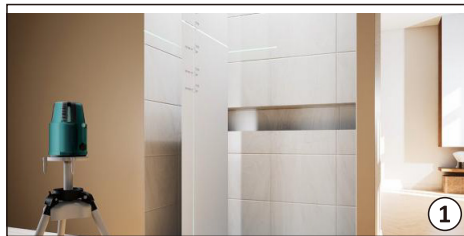

*Use a spirit level or laser level to measure the wall. Once aligned horizontally, attach the height template to both sides of the wall.

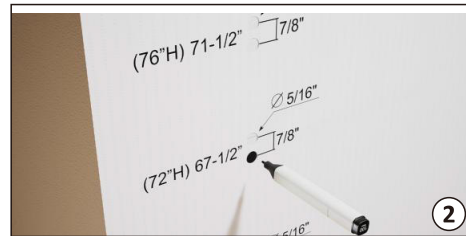

*Mark these locations with a pen, ensuring precision and clarity for accurate positioning during subsequent drilling.

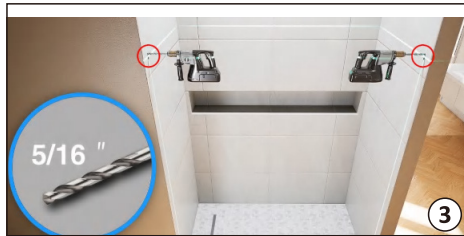

*Securely attach a 5/16" drill bit to the drill, ensuring it's firmly fastened. Then, carefully drill a hole at the marked location. When drilling into porcelain tiles, maintain a slow speed to prevent cracks.



*Insert the anchor into the hole.



*Disassemble the wall fittings.
*Put in the bumper and tighten the screws.



*Please note that the slot for mounting the accessory remains in the upper position.

STEP 2

Installation of upper horizontal header

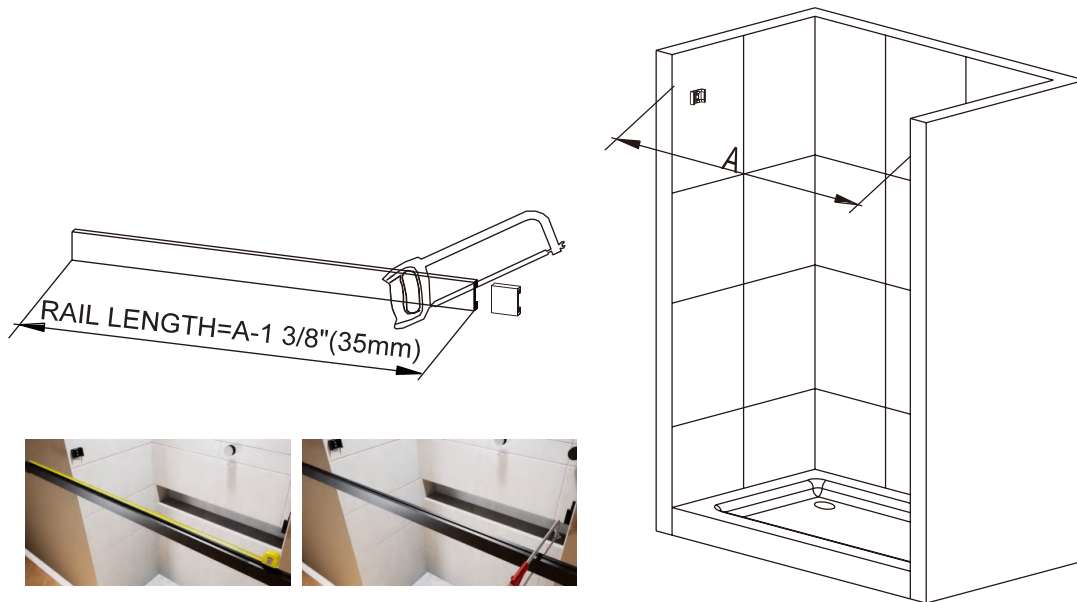

*Measure the desired length and use a saw to accurately cut the aluminum to size, ensuring the edges are smooth and flat.

STEP 3

Installation of upper horizontal header

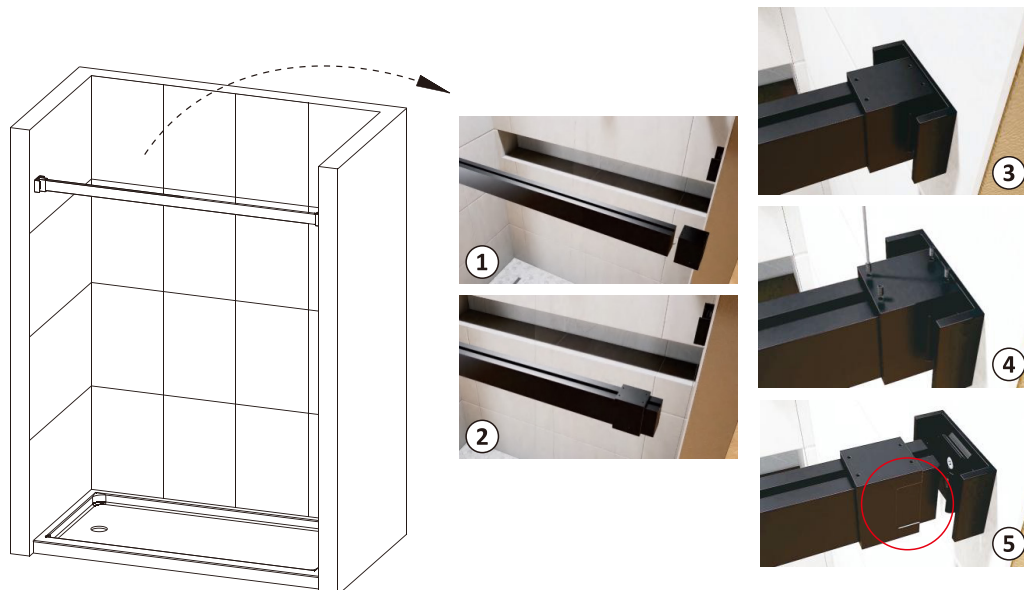

*Put the wall fittings in and torque the 4 screws to the right slot.
*Please put the groove of the accessory towards inside.

REMINDER

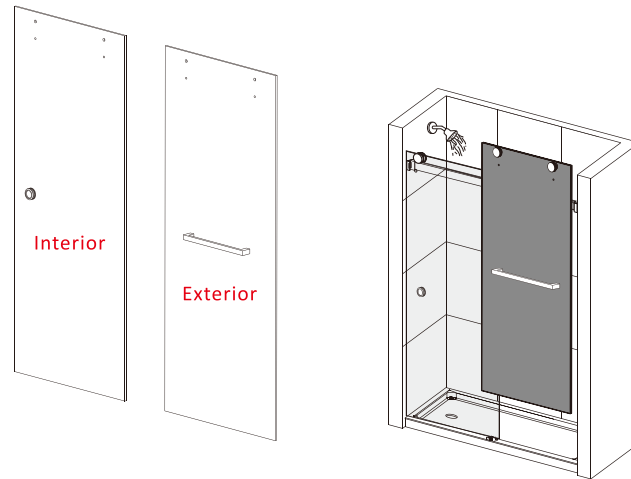

* Place the finger pull glass on the **inside** of the shower enclosure where the shower head is located, and place the towel bar glass on the **outside** of the enclosure.

STEP 4

Installation of pulley fittings

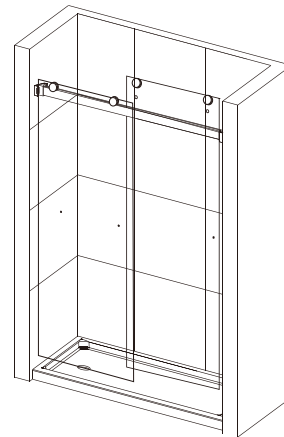

*Disassembly of pulley fittings.

*Place the pulleys in the correct order on the holes in the glass door, after tightening the pulleys using the screws and placing the inner glass inside. Please use a mat or soft cloth on the placement area to protect the door and the floor.

STEP 5

Installation of bottom retainer

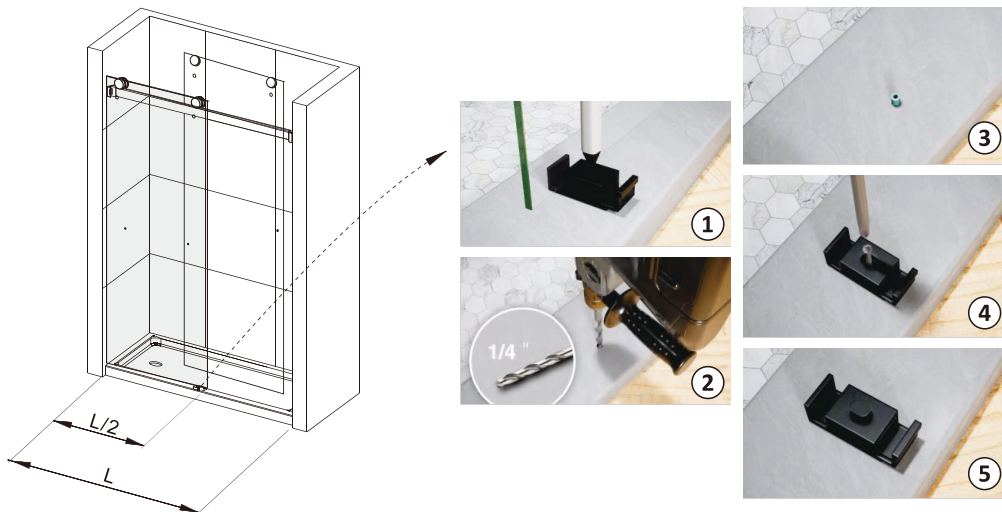

- *Secure the glass to the track first to ensure accurate installation of the bottom guide.
- *After confirming the position of $L/2$, place the bottom retainer in the middle position, measure with a level and make sure the glass is in horizontal and vertical level, then mark with a marker.
- *Drill the holes using a 1/4" drill bit, insert anchors in the holes, tighten the bottom retainer with screws, and close the decorative cover to complete the installation.

STEP 6

Installation of the glass door

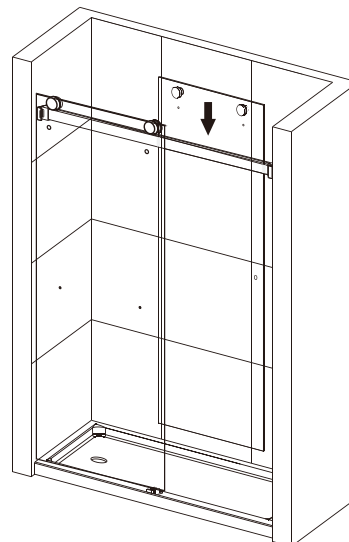

- *When installing the glass sliding door onto the sliding track, make sure that both wheels are correctly fitted to the sliding track and the glass is correctly fitted into the bottom fixer slot. Gently push the glass to check that it is sliding smoothly and also to ensure that it can be used safely.

STEP 7

The correct method of installing glass

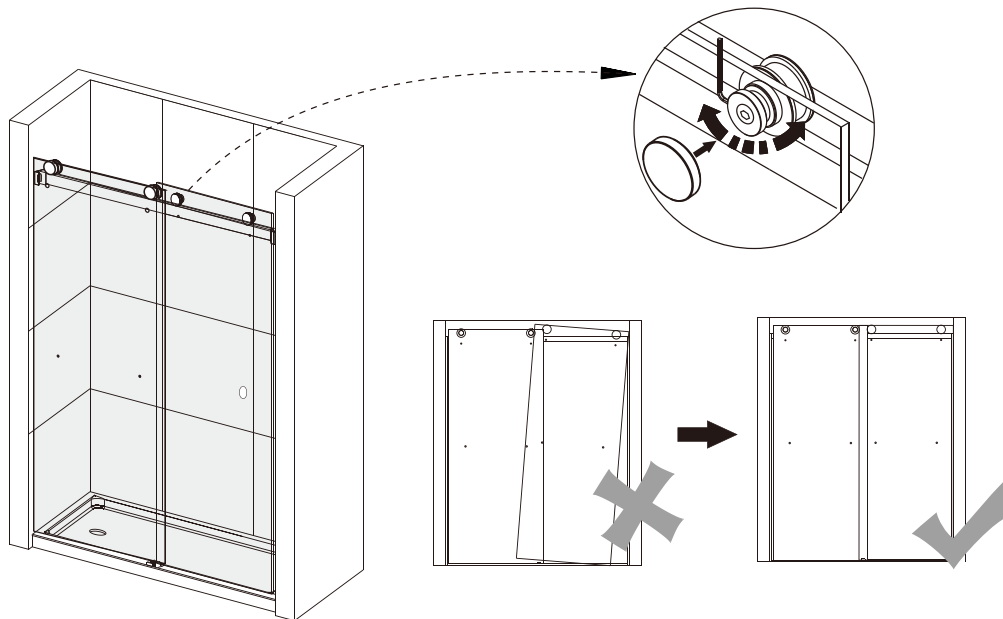

*If you notice that the glass is not level at the top and bottom, adjust the eccentric screw on the wheels to ensure the glass is level.

STEP 8

Installation of anti-jump nails

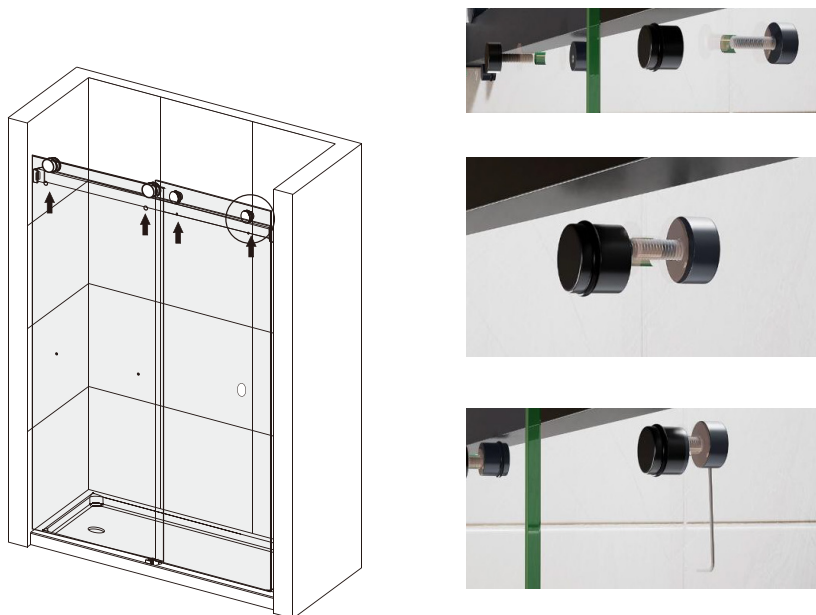

*After ensuring the glass is level, install anti-jump nails to prevent the glass from accidentally falling and causing injury.

STEP 9

Install plastic seal along the edges of both glass panels

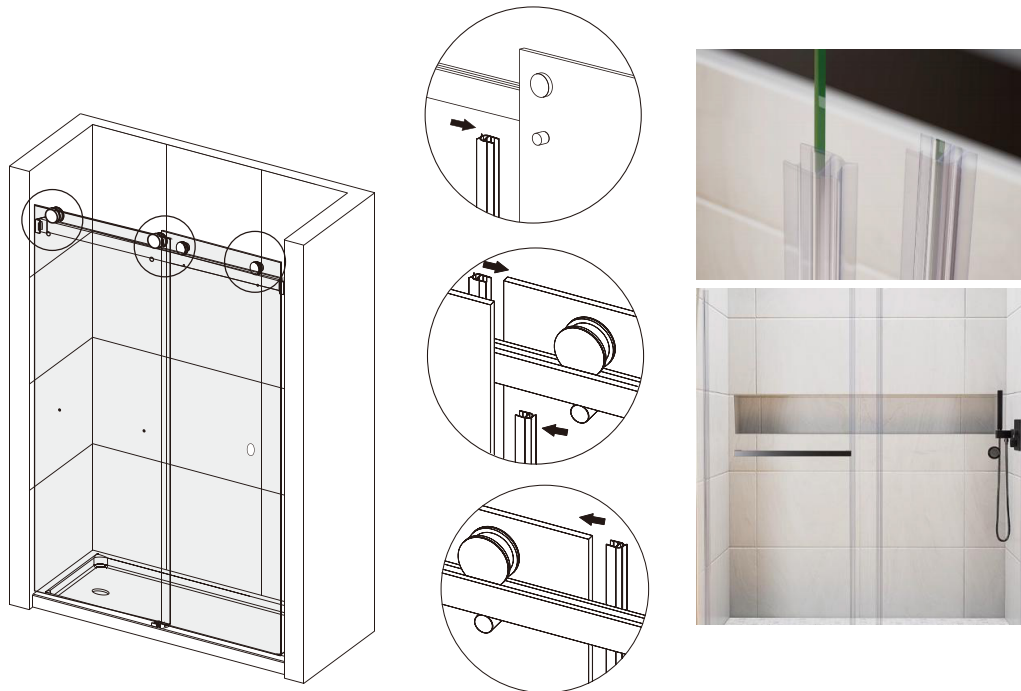

STEP 10

Installation of towel bar and knob

Towel bar installs on outside



Knob installs on inside

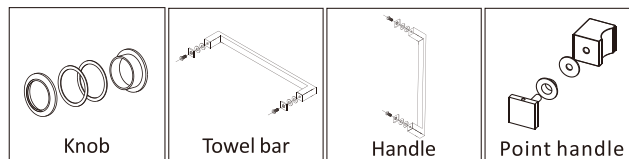
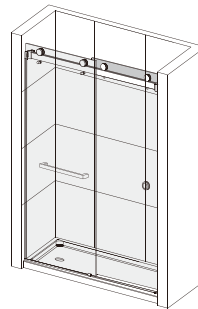

WARNING: Risk of SERIOUS INJURY. Do NOT install the towel bar, handle, or knob before the door is fully mounted. Lifting the door using these components can cause the door to shatter, resulting in severe injury.

STEP 11

Installation of the water stopper in the bottom fixture recess

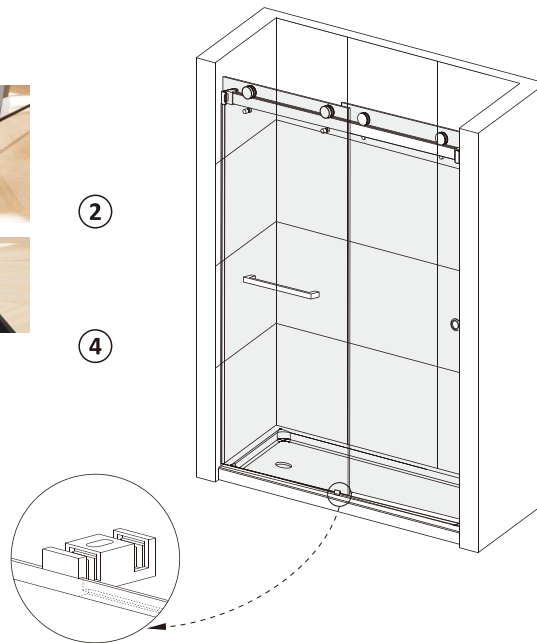
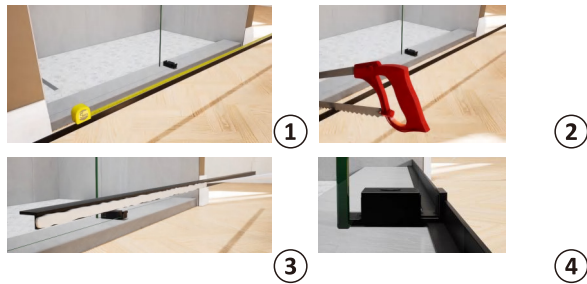

*Measure the desired length and use a saw to cut the threshold to the correct size. Ensure the edges are smooth and flat.

*To ensure the threshold functions properly, apply glass adhesive to fill the bottom gap completely. Covering the entire bottom surface.

*Install the water stopper in the bottom fixture recess and finish the installation by applying glass adhesive around the edges.

STEP 12

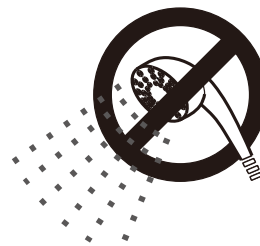
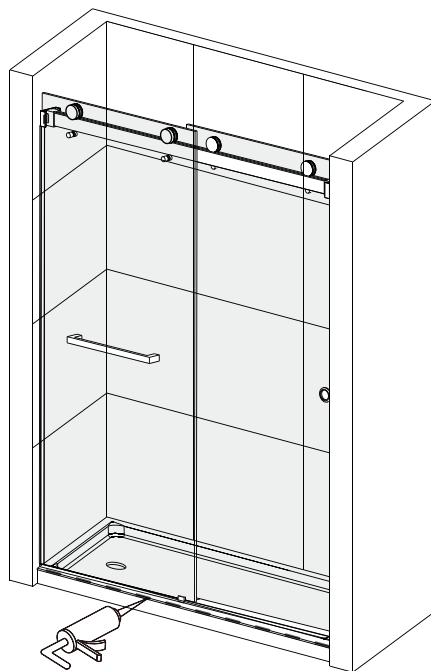

24 HOURS

*Wait 24 hours for the glass adhesive to cure.