

Legacy Series Full Backplate - Adjustable

SHOWER HINGE TEMPLATE



Wall Mount Hinge - Fullback Plate

SKU. LEG10-ADJ

Specifications:
Glass Sizes: 3/8" to 1/2" (10 to 12 mm) Tempered Glass Only
Construction: Solid Brass with HD Stainless Steel Back Plate
Closing Type: Self-Centering When Within 15 Degrees of Closed Position
Cutout Required: Cutout No. SD3
Includes: Hinge, glazing gaskets, wall mounting screws, allen head/phillips head cover plate screws, and fabrication template.
Use: Residential Bath and Commercial Hotel Applications

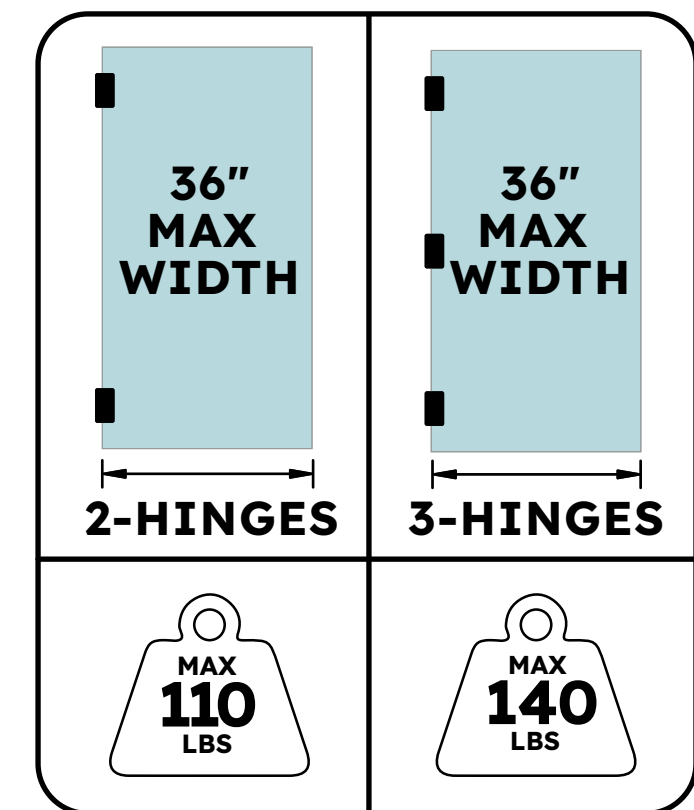
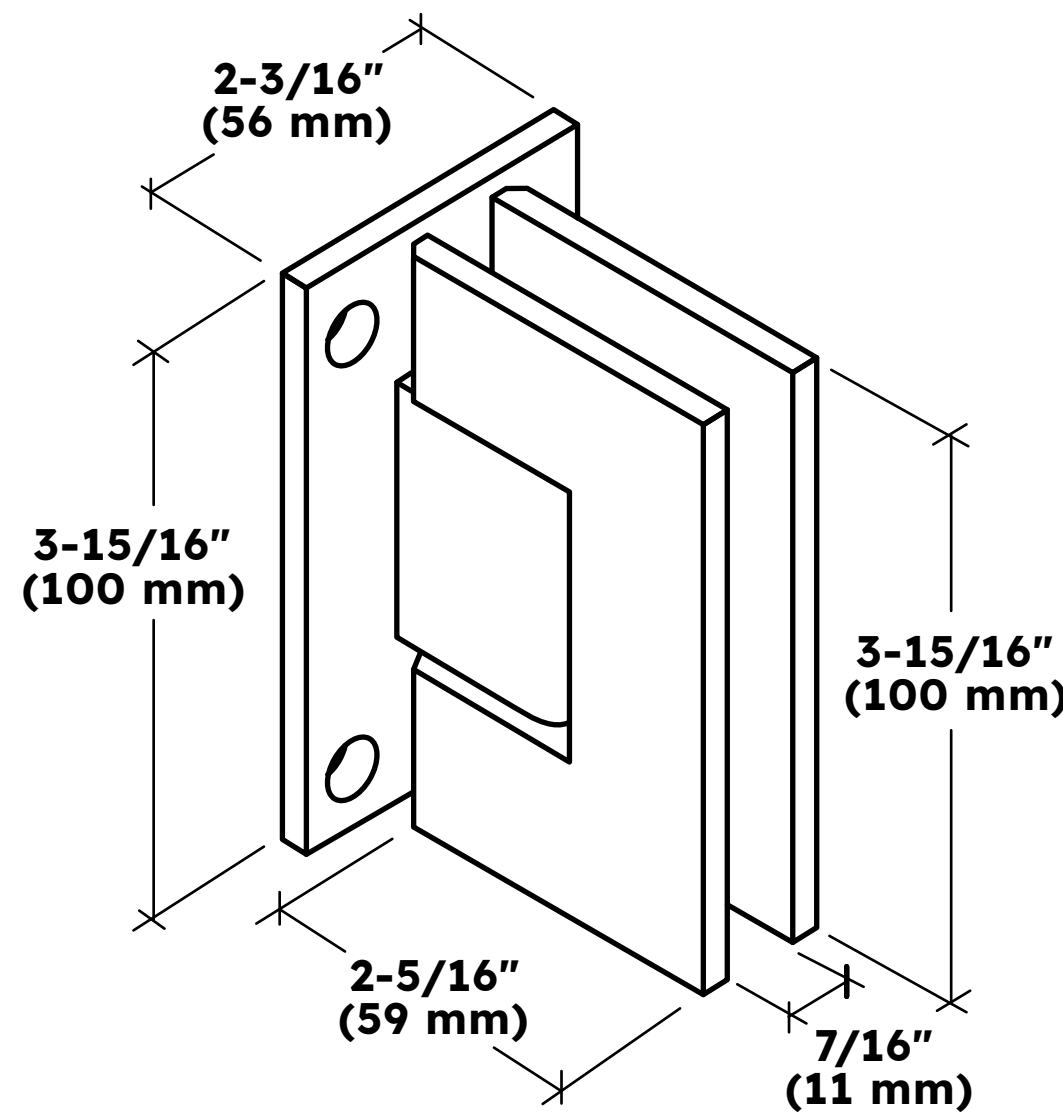

GASKET SPECIFICATIONS:

For 3/8" (10mm) Glass:
Use Two Thin Gaskets On Each Side

For 1/2" (12mm) Glass:
Use Two Thin Gaskets On Each Side

GLASS INSTRUCTIONS:

Only use tempered safety glass. To prevent damage to the hinge finish. Installing these hinges should not be performed with power tools.

IMPORTANT INFORMATION:

The Legacy Series Hinge has a dual-degree pivot pin. It comes factory set at 90 degrees for everyday door-closing applications. For jobs requiring firmer support against the jamb or seal, the hinge pivot pin can also be adjusted in the field to add an additional 5 degrees of closing.

SEE TEMPLATE ON BACK
Refer to Dimensions Shown to Ensure Accuracy

CARE & CLEANING GUIDELINES:

Keep the following recommendations in mind for maximum results when caring for your Glaze shower door hardware. Your shower door should be dried daily with a soft towel or cloth to ensure its original finish. Do not use harsh cleaners or chemicals on the hardware, as many of the components are coated with a clear lacquer that will become damaged beyond repair. Always test your cleaning solution in an inconspicuous area before wiping the entire hardware surface. Wipe surfaces with a soft, dampened cloth or sponge, and rinse with warm water immediately after applying the cleaning solution. Use only small amounts of a gentle, liquid cleaner. When cleaning hardware, don't use wire scrub brushes, or abrasive products.

MAXIMUM DOOR CAPACITY	3/8" (10MM) GLASS Approx. 5 lb/ft ²	1/2" (12 mm) GLASS Approx. 6.4 lb/ft ²
	DOOR WEIGHT	DOOR WIDTH
USING 2 HINGES	110 LBS. (50 kg)	36" (914 mm)
USING 3 HINGES	140 LBS. (64 kg)	36" (914 mm)
Note: Do not exceed either maximum weight or width when choosing proper quantity of hinges		

MAINTENANCE:

All Glaze Hardware hinges are factory greased to ensure a quiet, hassle-free installation. Suppose there is any noticeable squeaking that occurs after installation. In that case, applying a few drops of (3 in 1) multi-purpose oil to the hinge at the nylon washer/pivot location is recommended. If, for some reason, the hinge is disassembled during maintenance, use a small amount of white lithium grease to lubricate the interior hinge components. The lubricant will penetrate the hinge crevices, reducing friction and cleaning grime and buildup. The use of spray lubricants is prohibited.

Legacy Series Full Backplate - Adjustable

SHOWER CLAMP TEMPLATE



Wall Mount Hinge - Full Back Plate
SKU. LEG10-ADJ

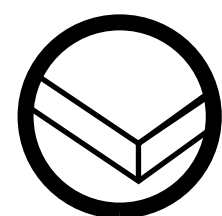

USE ONLY
MONOLITHIC
TEMPERED GLASS

Do not measure/scale drawing

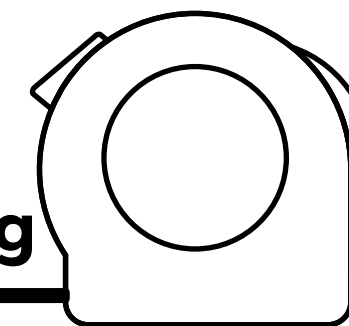

Use dimensions shown

Cutout No. SD3

