

# Legacy Series 180° Hinge - ADJ



SKU. LEG180-ADJ

## RECOMMENDATIONS:

Use only tempered safety glass.  
Do not use power tools for tightening the hinge clamping plate.

## MAINTENANCE GUIDELINES:

You should never apply an abrasive cleaner on hardware. Drying the hardware with a soft towel after each use is the most effective way to get the most out of our hardware. To clean our hardware a little bit of mild dish soap and warm water should

be applied using a non-abrasive cloth or towel. Rinse with clean warm water and then dry. Doing this after each use will ensure the longest life possible for the hardware. Leave the shower door slightly open to allow air to circulate; this will discourage the growth of mildew. Another important cleaning technique for shower doors is to squeegee after showering. It removes excess moisture from the shower and avoids water spots that can be difficult and almost impossible to remove. A plastic squeegee is best because it does not damage a shower door.

MAXIMUM DOOR CAPACITY	3/8" (10mm) GLASS		1/2" (12 mm) GLASS	
	WEIGHT	Width	WEIGHT	Width
USING 2 HINGES	110LBS.(50kg)	36*(914kg)	110LBS.(50kg)	36*(914kg)
USING 3 HINGES	140LBS.(64kg)	36*(914kg)	140LBS.(64kg)	36*(914kg)

Note: Do not exceed either maximum weight or width when choosing proper quantity of hinges

SEE TEMPLATE ON BACK  
Refer to Dimensions Shown  
to Ensure Accuracy

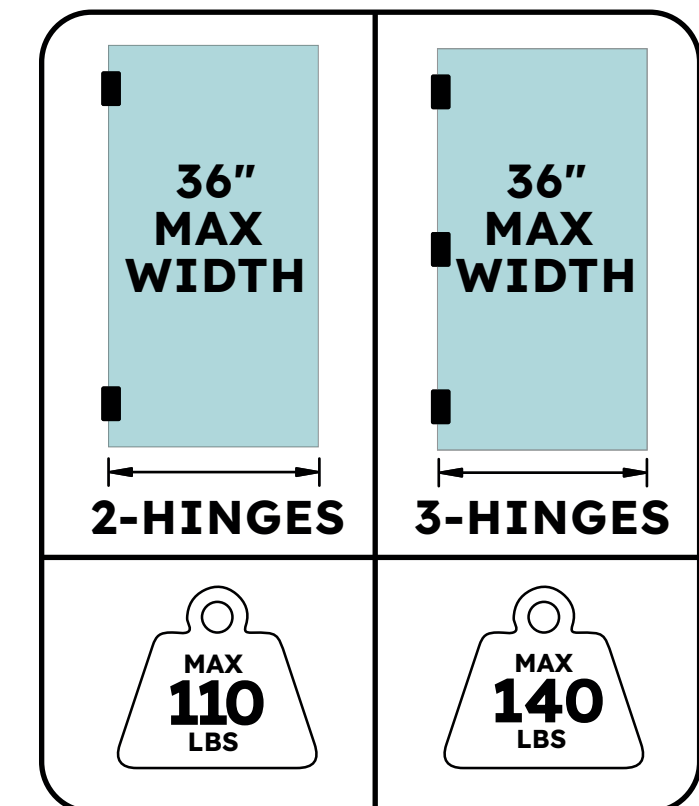
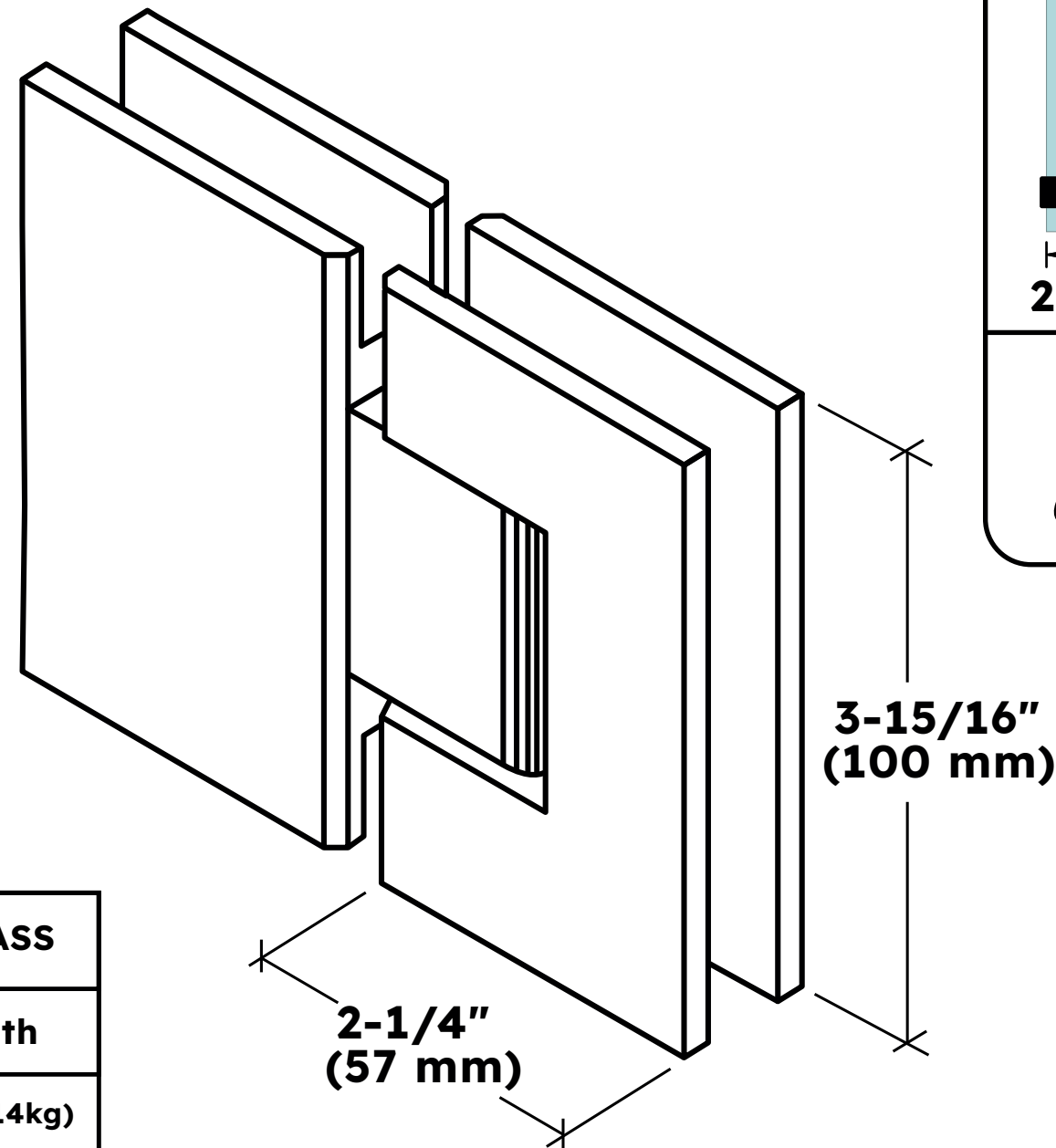

Adjustable

## Specifications:

Glass Sizes: 3/8" (10mm) to 1/2" (12mm) thick tempered safety glass  
Construction: Solid brass  
Cutout Required  
Includes: Gaskets, screws and template

Use of Gaskets:  
For 3/8"(10mm) Glass: Use one thick gasket on each side  
For 1/2"(12mm) Glass: Use one thin gasket on each side

