

# Majesty Series Standard Duty

## SHOWER HINGE TEMPLATE



### Glass to Glass Transom Hinge

SKU:MAJGTG180T

### RECOMMENDATIONS:

Use only tempered safety glass.  
Do not use power tools for tightening the hinge clamping plate

### MAINTENANCE GUIDELINES:

All Glaze Hardware hinges are factory greased to ensure a quiet, hassle-free installation. Suppose there is any noticeable squeaking that occurs after installation. In that case, applying a few drops of (3 in 1) multi-purpose oil to the hinge at the nylon washer/pivot location is recommended. If, for some reason, the hinge is disassembled during maintenance, use a small amount of white lithium grease to lubricate the interior hinge components. The lubricant will penetrate the hinge crevices, reducing friction and cleaning grime and buildup. The use of spray lubricants is prohibited.

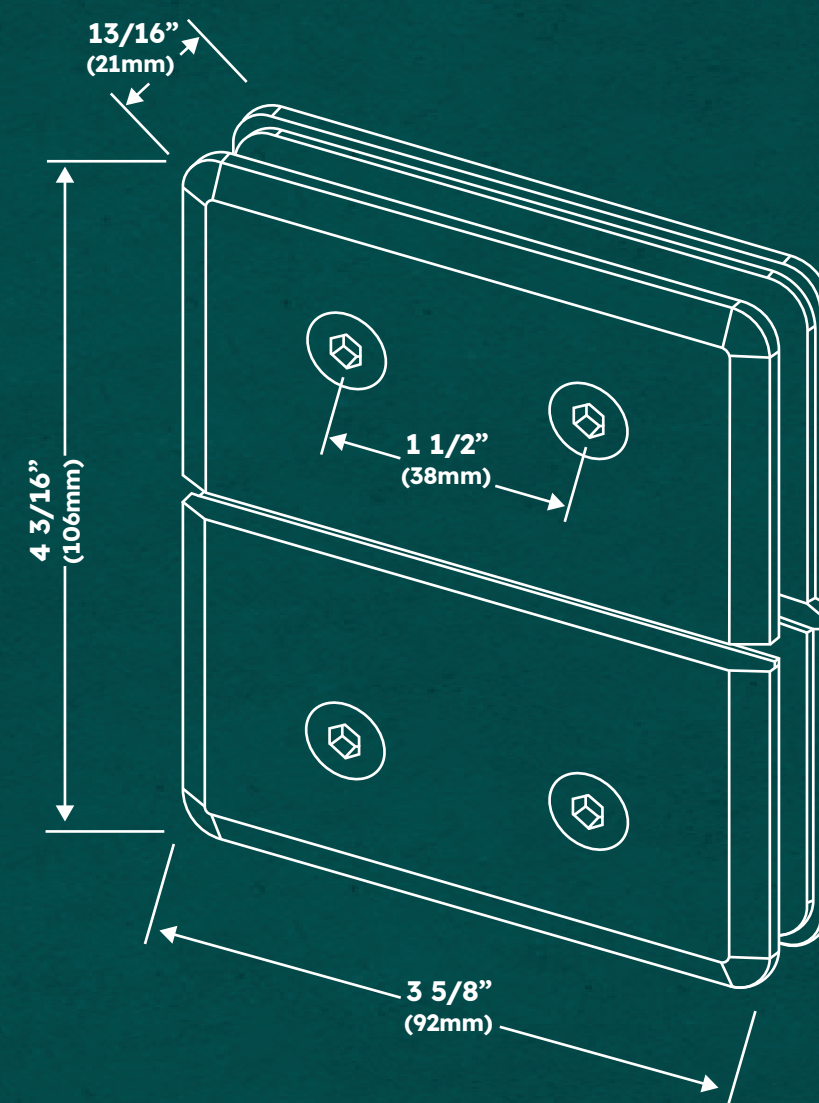

**SEE TEMPLATE BELOW**  
Refer to Dimensions Shown to Ensure Accuracy

### Specifications:

**Glass Sizes:** 3/8" (10mm) to 1/2 (12mm) thick tempered safety glass

**Construction:** Solid brass  
Cutout Required

**Includes:** Gaskets, screws and template

**Use of Gaskets:**

For 3/8" (10mm) Glass: Use one thick gasket on each side  
For 1/2 (12mm) Glass: Use one thick gasket on each side

