

Regal Series

180° Glass to Glass Hinge Beveled

SHOWER HINGE TEMPLATE



SKU. REG180

RECOMMENDATIONS:

Use only tempered safety glass.
Do not use power tools for tightening the regal clamping plate

MAINTENANCE GUIDELINES:

You should never apply an abrasive cleaner on hardware. Drying the hardware with a soft towel after each use is the most effective way to get the most out of our hardware. To clean our hardware a little bit of mild dish soap and warm water should be applied using a non-abrasive cloth or towel. Rinse with clean warm water and then dry. Doing this after each use will ensure the longest life possible for the hardware. Leave the shower door slightly open to allow air to circulate; this will discourage the growth of mildew. Another important cleaning technique for shower doors is to squeegee after showering. It removes excess moisture from the shower and avoids water spots that can be difficult and almost impossible to remove. A plastic squeegee is best because metal could damage a shower.

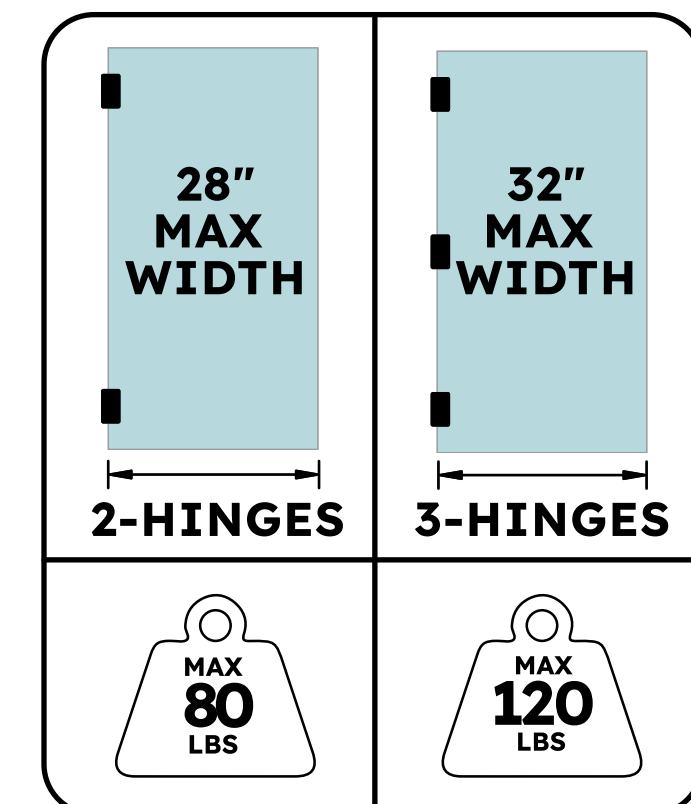
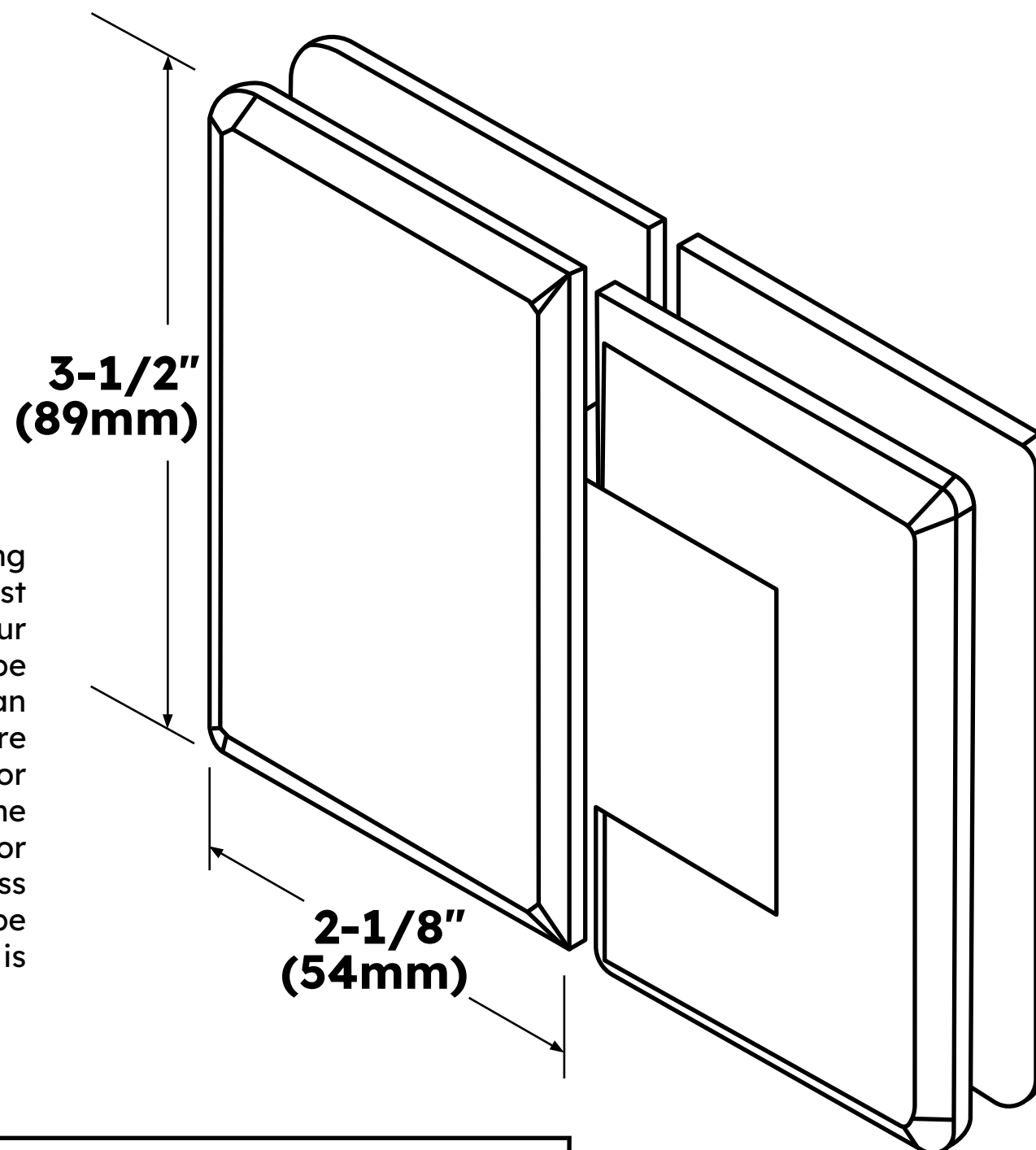

MAXIMUM DOOR CAPACITY	3/8" (10mm) GLASS		1/2" (12mm) GLASS	
	WEIGHT	WIDTH	WEIGHT	WIDTH
USING 2 HINGES	80 LBS (36 Kg)	28" (711 mm)	80 LBS (36 Kg)	28" (711 mm)
USING 3 HINGES	120 LBS (54 Kg)	32" (813 mm)	120 LBS (54 Kg)	32" (813 mm)

Note: Do not exceed either maximum weight or width when choosing proper quantity of hinges.



SEE TEMPLATE ON BACK
Refer to Dimensions Shown
to Ensure Accuracy

SPECIFICATIONS:

Glass Sizes: 3/8" (10mm) to 1/2" (12mm) thick tempered safety glass
Construction: Solid brass
Closing Type: Self-centering when within 15° of closed position
Cutout Required
Includes: Gaskets, screws and template
Use of Gaskets: 15% of closed position, urethane gasket on each side
For 3/8" (10mm) Glass: Use one thick gasket on each side
For 1/2" (12mm) Glass: Use one thin gasket on each side

