

# Square 135 Closed Face Clamp Glass to Glass



SKU. SGC535-CF

## Recommendations:

Use only tempered safety glass.  
Do not use power tools for tightening the Clamp clamping plate

## Maintenance guidelines:

You should never apply an abrasive cleaner on hardware. Drying the hardware with a soft towel after each use is the most effective way to get the most out of our hardware. To clean our hardware a little bit of mild dish soap and warm water should be applied using a nonabrasive cloth or towel. Rinse with clean warm water and then dry. Doing this after each use will ensure the longest life possible for the hardware. Leave the shower door slightly open to allow air to circulate; this will discourage the growth of mildew. Another important cleaning technique for shower doors is to squeegee after showering. It removes excess moisture from the shower and avoids water spots that can be difficult and almost impossible to remove. A plastic squeegee is best because metal could damage a shower.

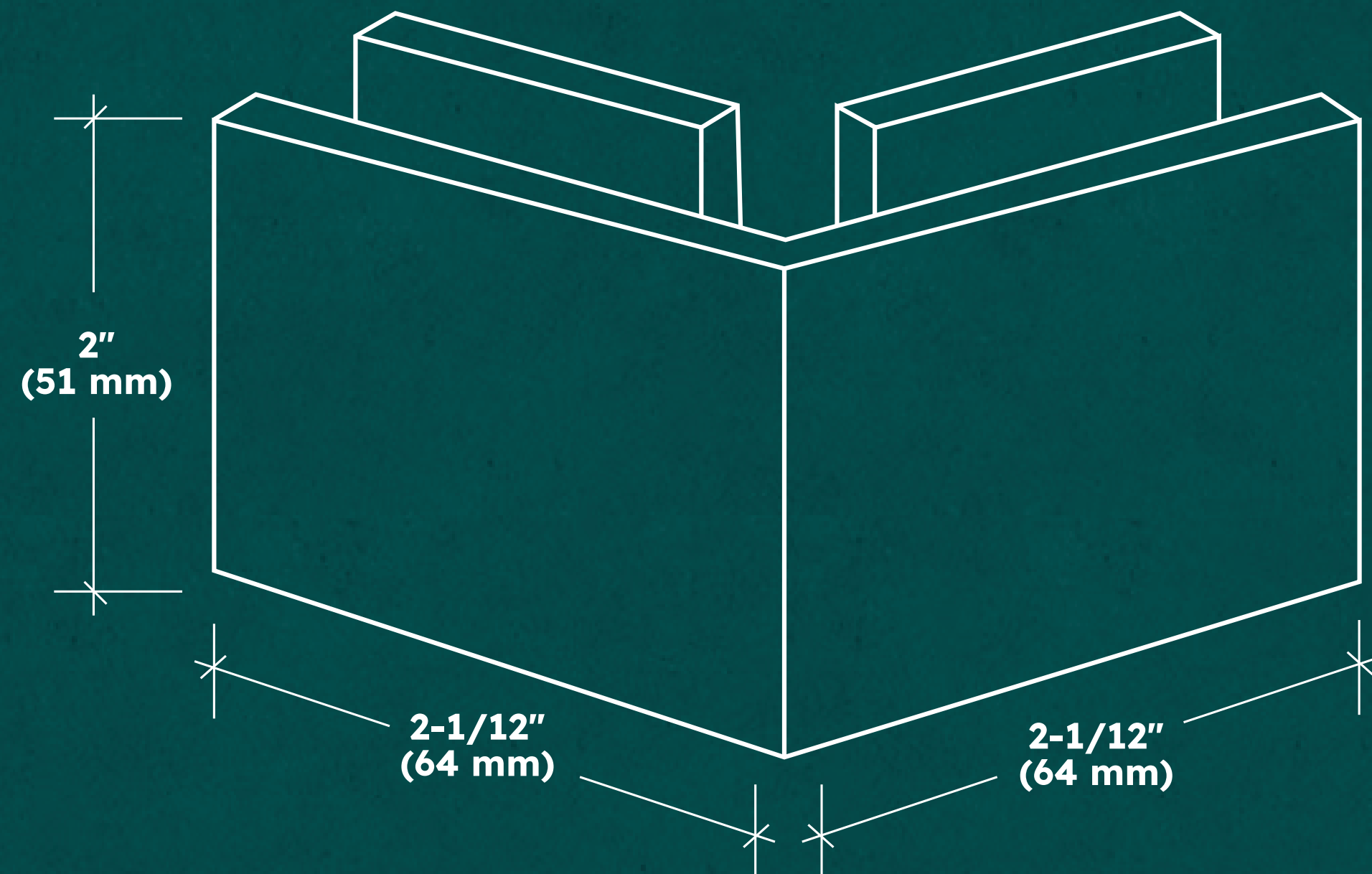

Front View

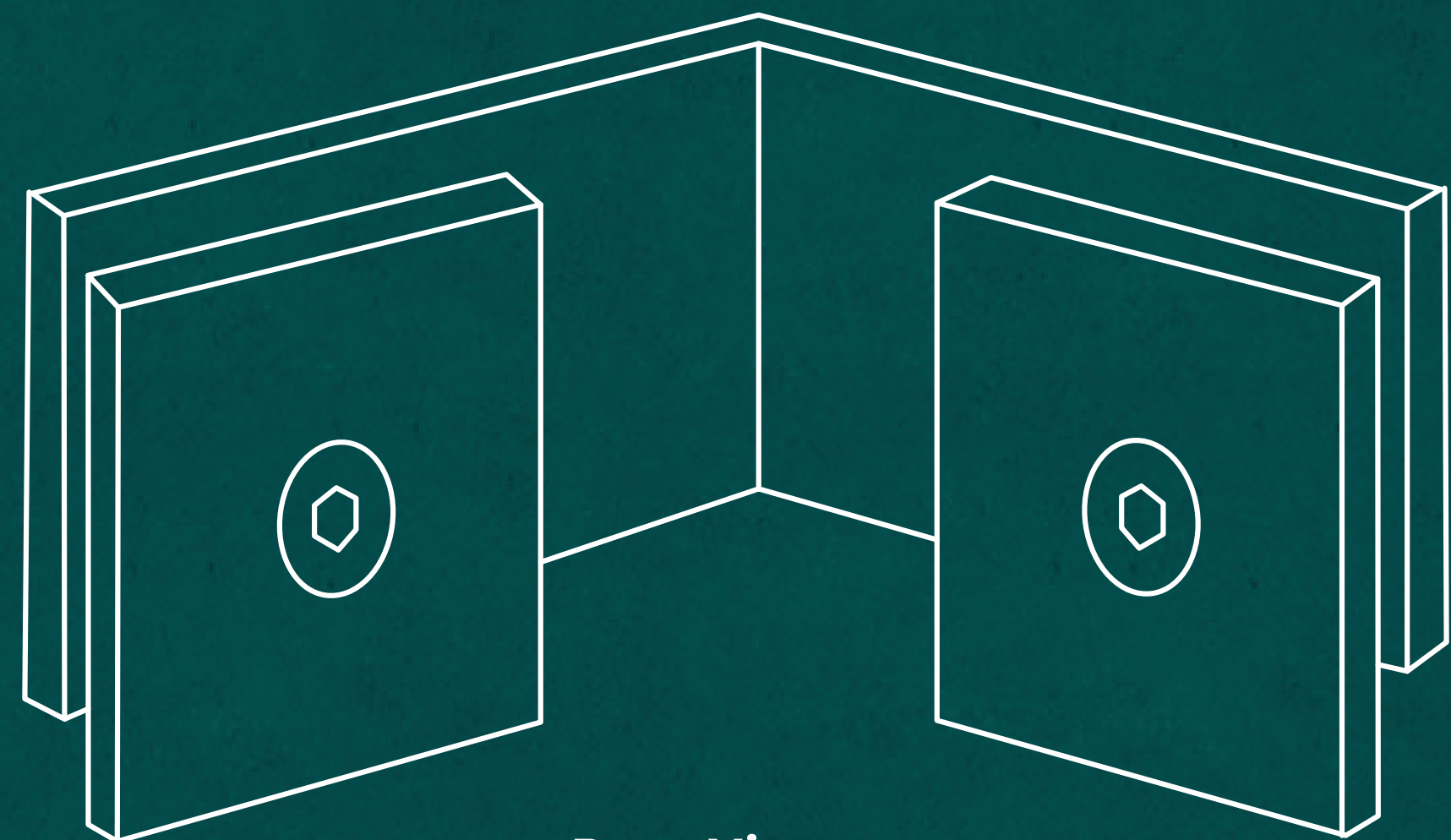

Rear View

## Specifications:

**Glass Sizes:** 3/8" (10mm) to 1/2" (12mm) thick tempered safety glass

**Construction:** Solid brass  
Cutout Required

**Includes:** Gaskets, screws and template

### Use of Gaskets:

**For 3/8" (10mm) Glass:** Use one thick gasket on each side

**For 1/2" (12mm) Glass:** Use one thin gasket on each side

# Square 135 Closed Face Clamp Glass to Glass



SKU. SGC535-CF

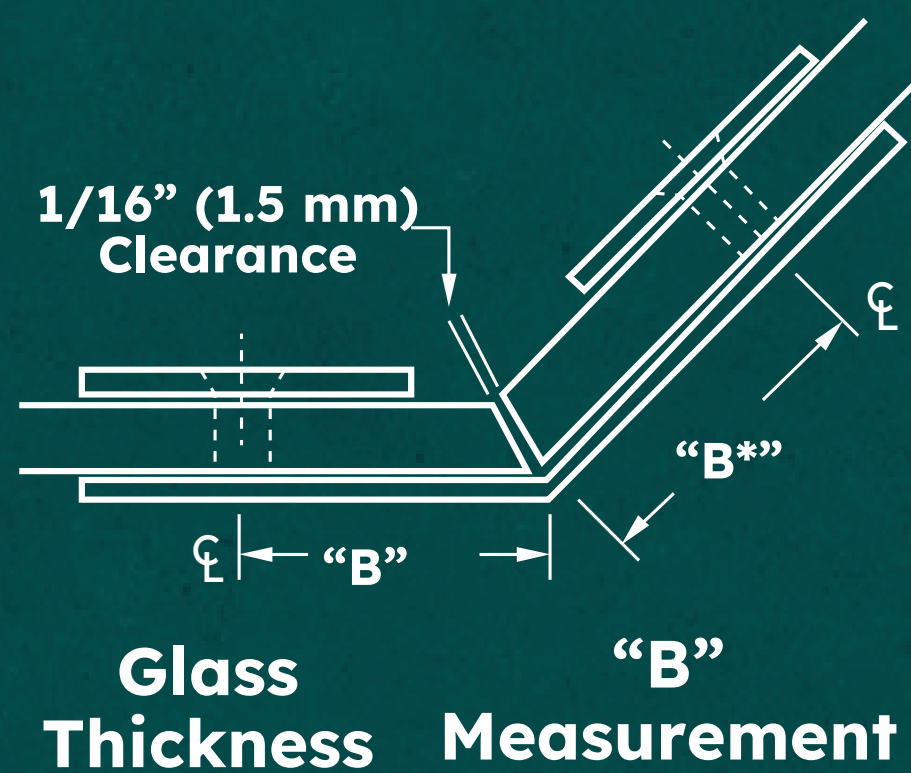

Glass Thickness	"B" Measurement
3/8" (10 mm)	1-7/16" (37mm)
1/2" (12 mm)	1-7/16" (37 mm)

## Mitered Template

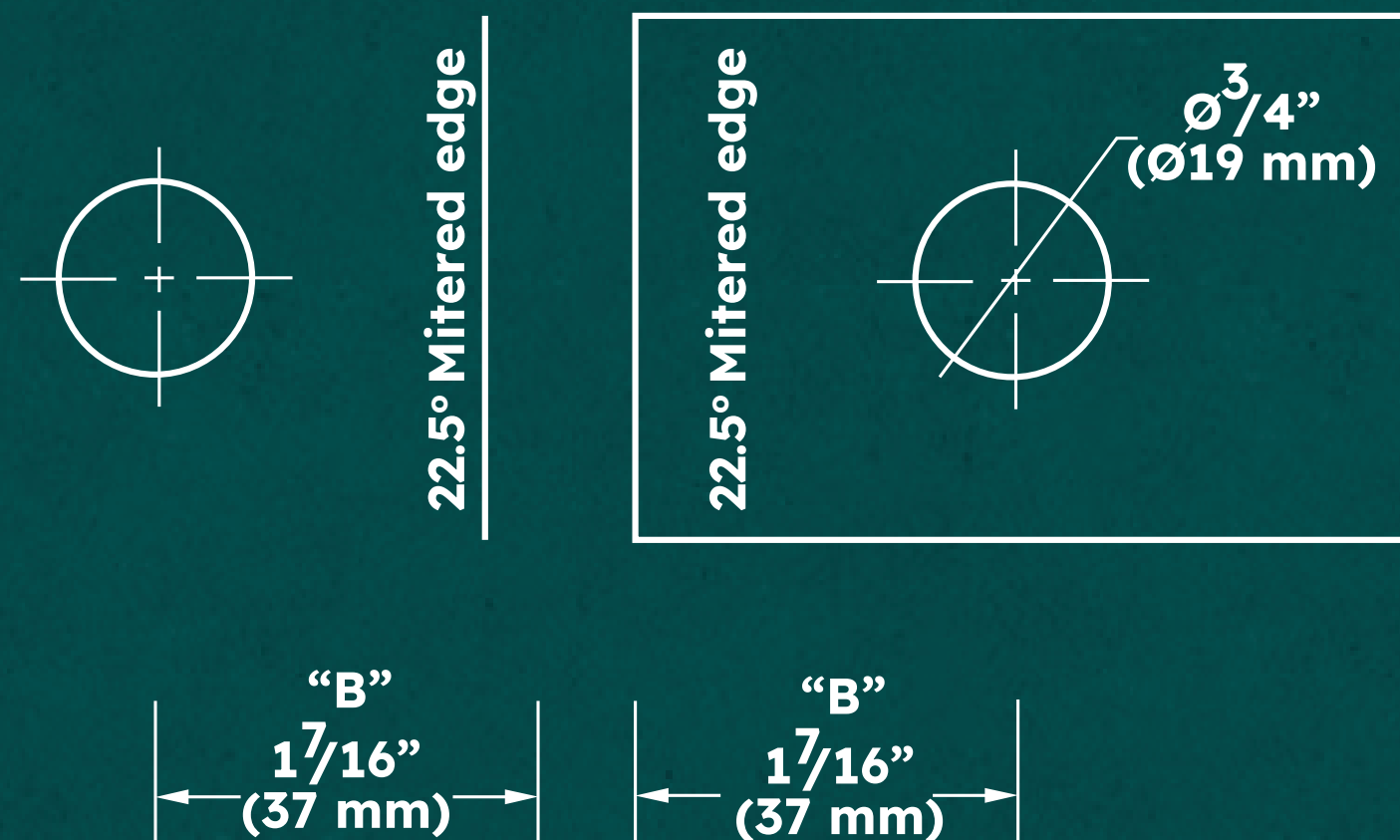

## Square Cut Template

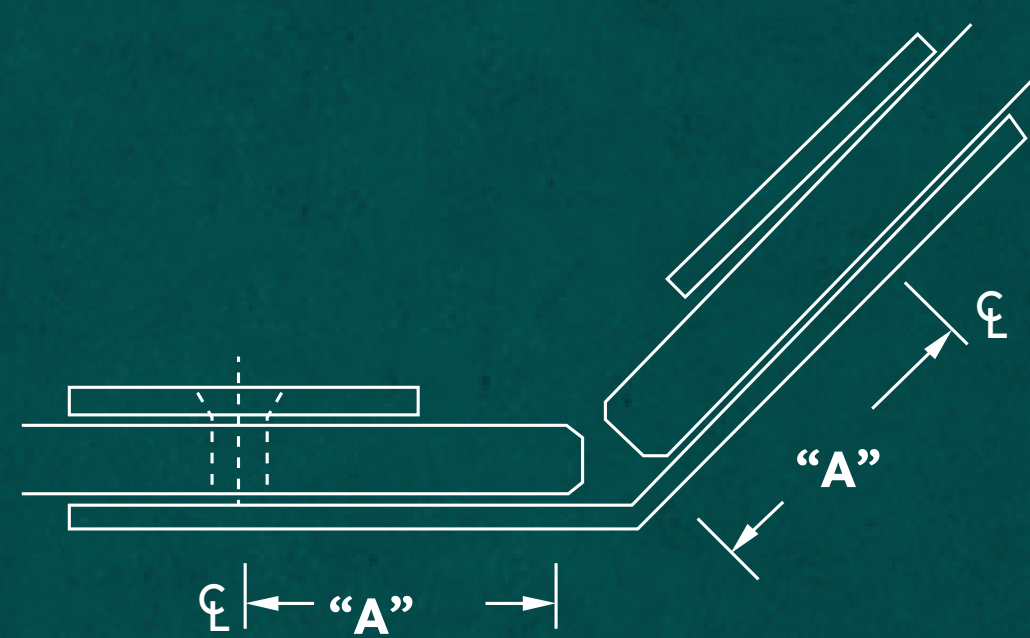

Glass Thickness	"A" Measurement
3/8" (10 mm)	1-7/16" (37mm)
1/2" (12 mm)	1-7/16" (37 mm)

