

Sublime Series Offset

SHOWER HINGE TEMPLATE



Hinge - Adjustable

SKU: SUB10-OS-ADJ

RECOMMENDATIONS:

Use only tempered safety glass.
Do not use power tools for tightening the hinge clamping plate

MAINTENANCE GUIDELINES:

All Glaze Hardware hinges are factory greased to ensure a quiet, hassle-free installation. Suppose there is any noticeable squeaking that occurs after installation. In that case, applying a few drops of (3 in 1) multi-purpose oil to the hinge at the nylon washer/pivot location is recommended. If, for some reason, the hinge is disassembled during maintenance, use a small amount of white lithium grease to lubricate the interior hinge components. The lubricant will penetrate the hinge crevices, reducing friction and cleaning grime and buildup. The use of spray lubricants is prohibited.

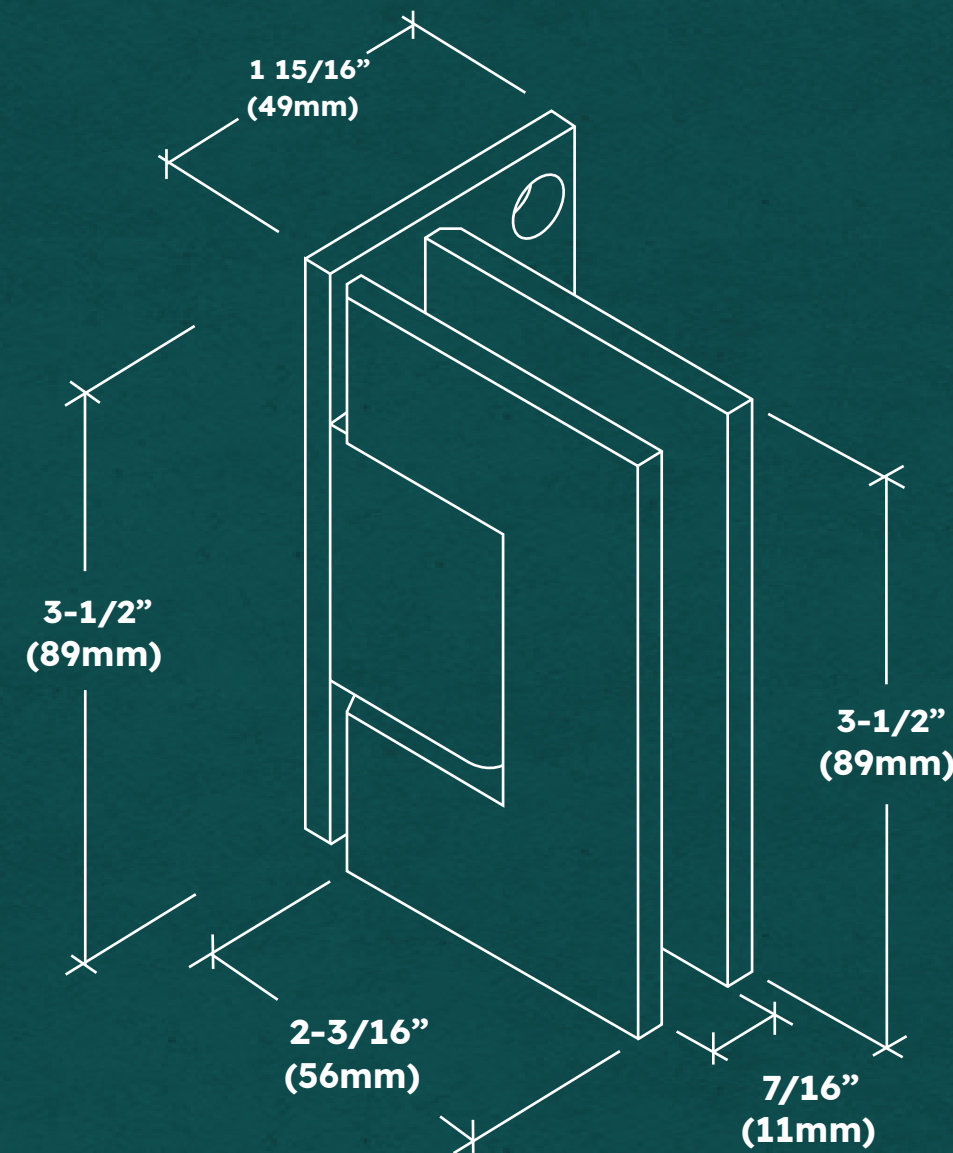

SEE TEMPLATE BELOW
Refer to Dimensions Shown to Ensure Accuracy

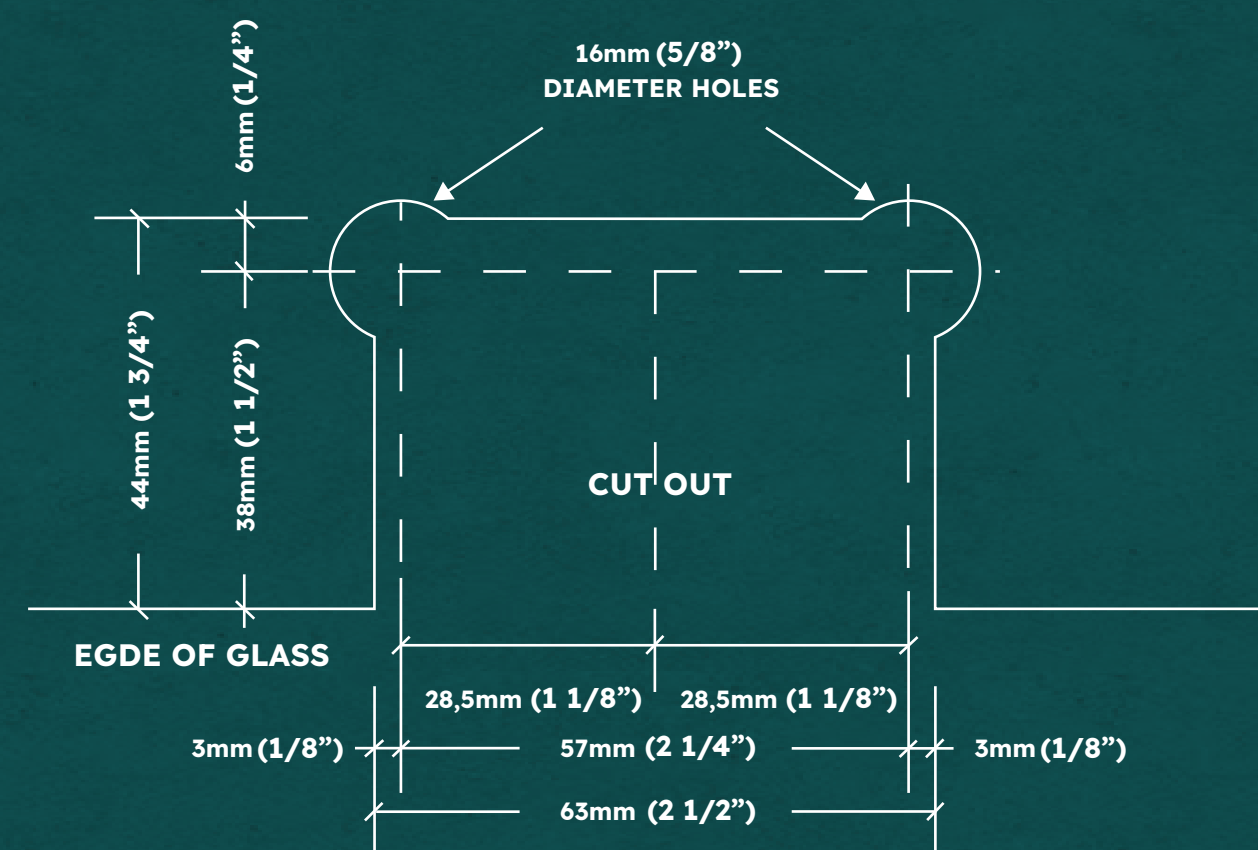

Specifications:

Glass Sizes: 3/8" (10mm) to 1/2" (12mm) thick tempered safety glass

Construction: Solid brass
Cutout Required

Includes: Gaskets, screws and template

Use of Gaskets:

Our Military Grade Gasket can be used with 3/8" and 1/2" thick glass

MAXIMUM DOOR CAPACITY	3/8 (10MM) GLASS		1/2 (12MM) GLASS	
	WEIGHT	WIDTH	WEIGHT	WIDTH
USING 2 HINGES	80 LBS (36 Kg)	28" (711 mm)	80 LBS (36 Kg)	28" (711 mm)
USING 3 HINGES	120 LBS (54 Kg)	32" (813 mm)	120 LBS (54 Kg)	32" (813 mm)

Note: Do not exceed either maximum weight or width when choosing proper quantity of hinges.